

# Stretch Panel Family

Specifications



## Stretch Panel Family

Our range of native stretch LCD panels presents you with many innovative ways to capture your target audience attention. These stretched panels, also known as bar displays and are available in a variety of sizes 19" - 48". Additional cut sizes available on request. There are a variety of configurations, and brightness options making them a perfect versatile solution for your digital signage requirements. Our display's stretched panels are utilised in retail, advertising, transport, food and beverage and many other environments worldwide.

### Key Features



Android Media  
Player



24/7 Usage

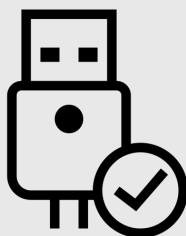

Plug and Play

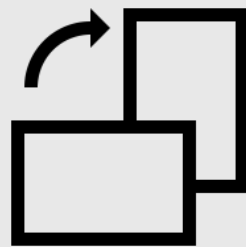

Landscape or  
Portrait

VIPS

Commercial IPS

Call Us: [+44 \(0\)870 005 5520](tel:+44208700055520)



Email: [eva2@adseries.com](mailto:eva2@adseries.com)

# Stretch Panel Family

Specifications



Screen size								
Screen Size	19"	21.2"	24"	28"	36.6"	37"	48"	
Product Number	AD190-300-MOF-V2	AD212-450-MOF-V2	AD240-300-MOF-V4	AD280-700-MOF-V2	AD366-700-MOF-V2	AD370-700-MOF-V2	AD480-1000-MOF-V2	
Panel								
Resolution	1920 x 360	1920 x 360	1920 x 360	1920 x 360	1920 x 290	1920 x 540	3840 x 720	
Viewing Angle	89 / 89 / 89 / 89	89 / 89 / 89 / 89	89 / 89 / 89 / 89	89 / 89 / 89 / 89	89 / 89 / 89 / 89	89 / 89 / 89 / 89	89 / 89 / 89 / 89	
Active Area	476.64 x 89.37	529.416 x 99.2655	597.88 x 112.1	699.84 x 131.22	919.3 x 138.85	899.712 x 253.044	1194.05 x 223.88	
Outer Dimensions	494.9 x 112.8 x 30	546.9 x 121.9 x 29.2	616.1 x 135.5 x 30	735.4 x 168.4 x 34	963.4 x 177.75 x 34.1	918.3 x 284.3 x 40	1221.3 x 251.6 x 47.28	
Brightness	300	450	300	700	700	700	1000	
Contrast	1200:1	1200:1	1200:1	1200:1	1200:1	1000:1	1000:1	
General Information								
Response Time	30	8	30	6.5	8	14	10	
Overall Weight	1000	1363.5	1815	3900	5100	7560	5550	
Operational Temp	0-50	0-50	0-50	0-50	0-50	0-50	0-50	
Storage Temp	-20 - 60	-20 - 60	-20 - 60	-20 - 60	-20 - 60	-20 - 60	-20 - 60	



\*Specifications are typical and subject to change.

Call Us: +44 (0)870 005 5520



Email: [eva2@adseries.com](mailto:eva2@adseries.com)

# 19" Stretch Panel

Product Number - AD190-300-MOF-V2



Specifications

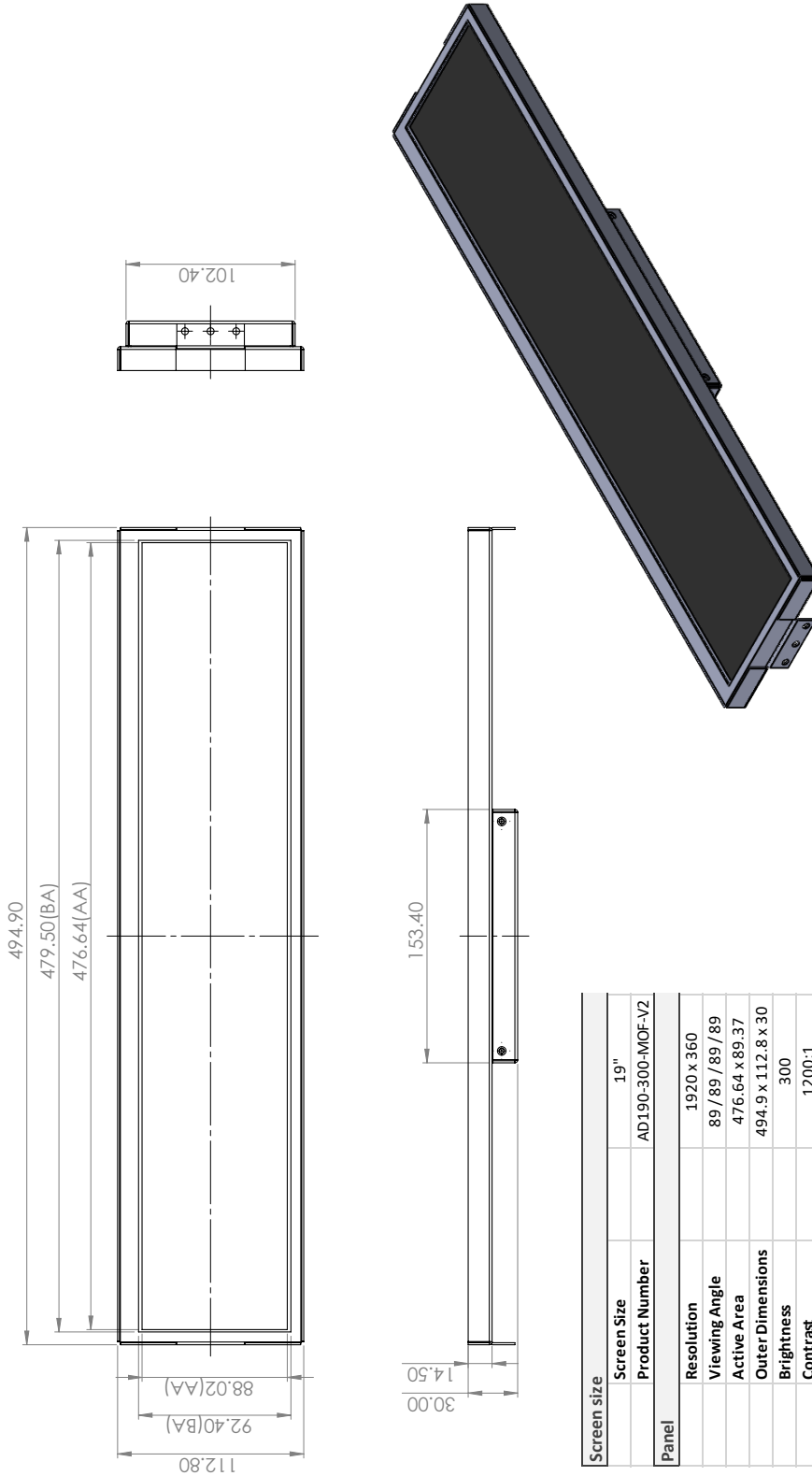

Screen size	19"
Product Number	AD190-300-MOF-V2
<b>Panel</b>	
Resolution	1920 x 360
Viewing Angle	89 / 89 / 89 / 89
Active Area	476.64 x 89.37
Outer Dimensions	494.9 x 112.8 x 30
Brightness	300
Contrast	1200:1
<b>General Information</b>	
Response Time	30
Overall Weight	1000
Operational Temp	0-50
Storage Temp	-20 - 60

\*Specifications are typical and subject to change.

# 21.2" Stretch Panel

Product Number – AD212-450-MOF-V2

Specifications

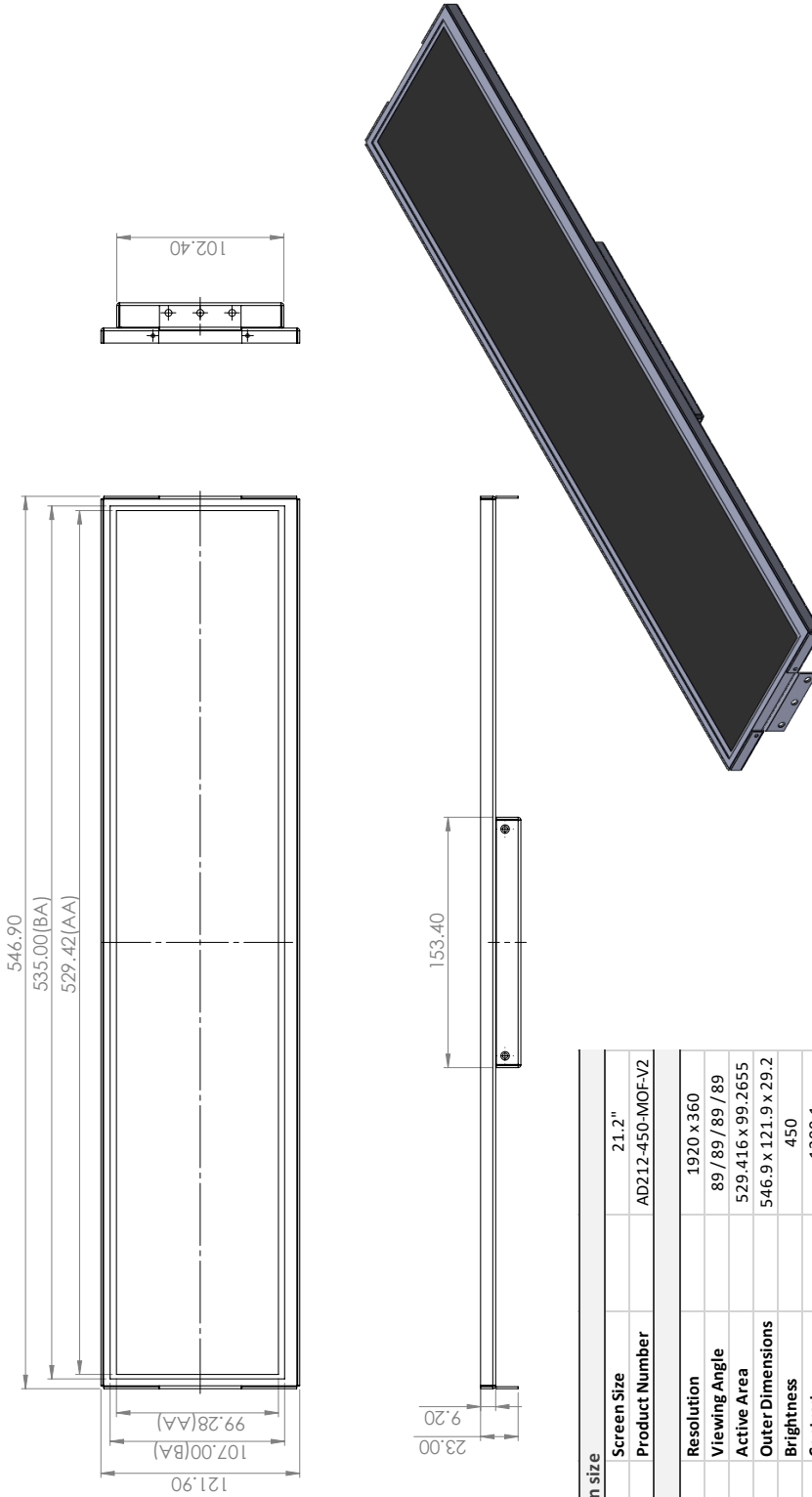

Screen size	21.2"
Product Number	AD212-450-MOF-V2
<b>Panel</b>	
Resolution	1920 x 360
Viewing Angle	89 / 89 / 89 / 89
Active Area	529.416 x 99.2655
Outer Dimensions	546.9 x 121.9 x 29.2
Brightness	450
Contrast	1200:1
<b>General Information</b>	
Response Time	8
Overall Weight	1363.5
Operational Temp	0-50
Storage Temp	-20 - 60

\*Specifications are typical and subject to change.

# 24" Stretch Panel

Product Number – AD240-300-MOF-V4

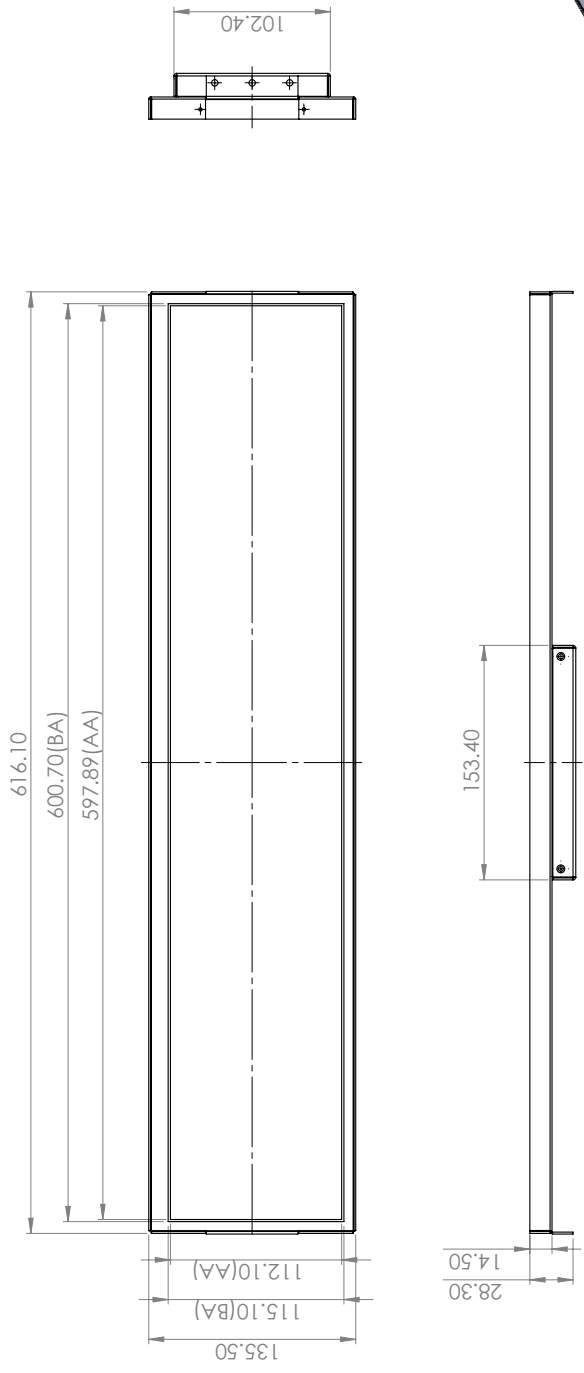
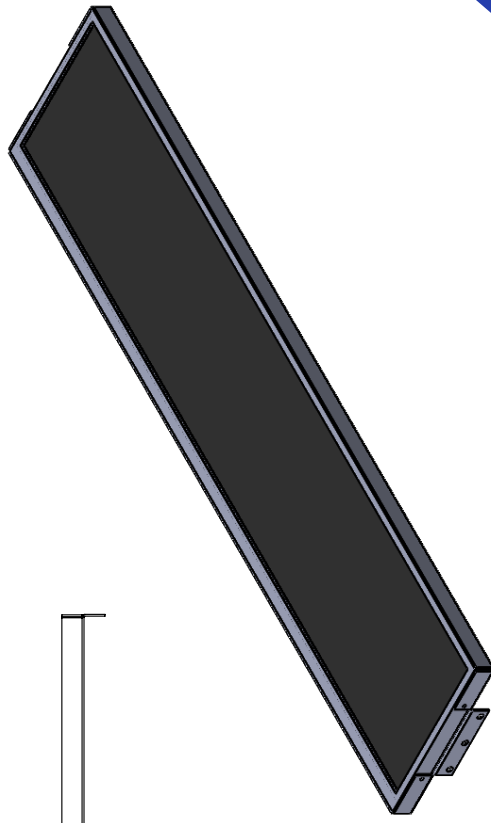

Screen size	24"
Product Number	AD240-300-MOF-V4
<b>Panel</b>	
Resolution	1920 x 360
Viewing Angle	89 / 89 / 89 / 89
Active Area	597.88 x 112.1
Outer Dimensions	616.1 x 135.5 x 30
Brightness	300
Contrast	1200:1
<b>General Information</b>	
Response Time	30
Overall Weight	1815
Operational Temp	0-50
Storage Temp	-20 - 60

\*Specifications are typical and subject to change.

# 28" Stretch Panel

Product Number – AD280-700-MOF-V2

Specifications

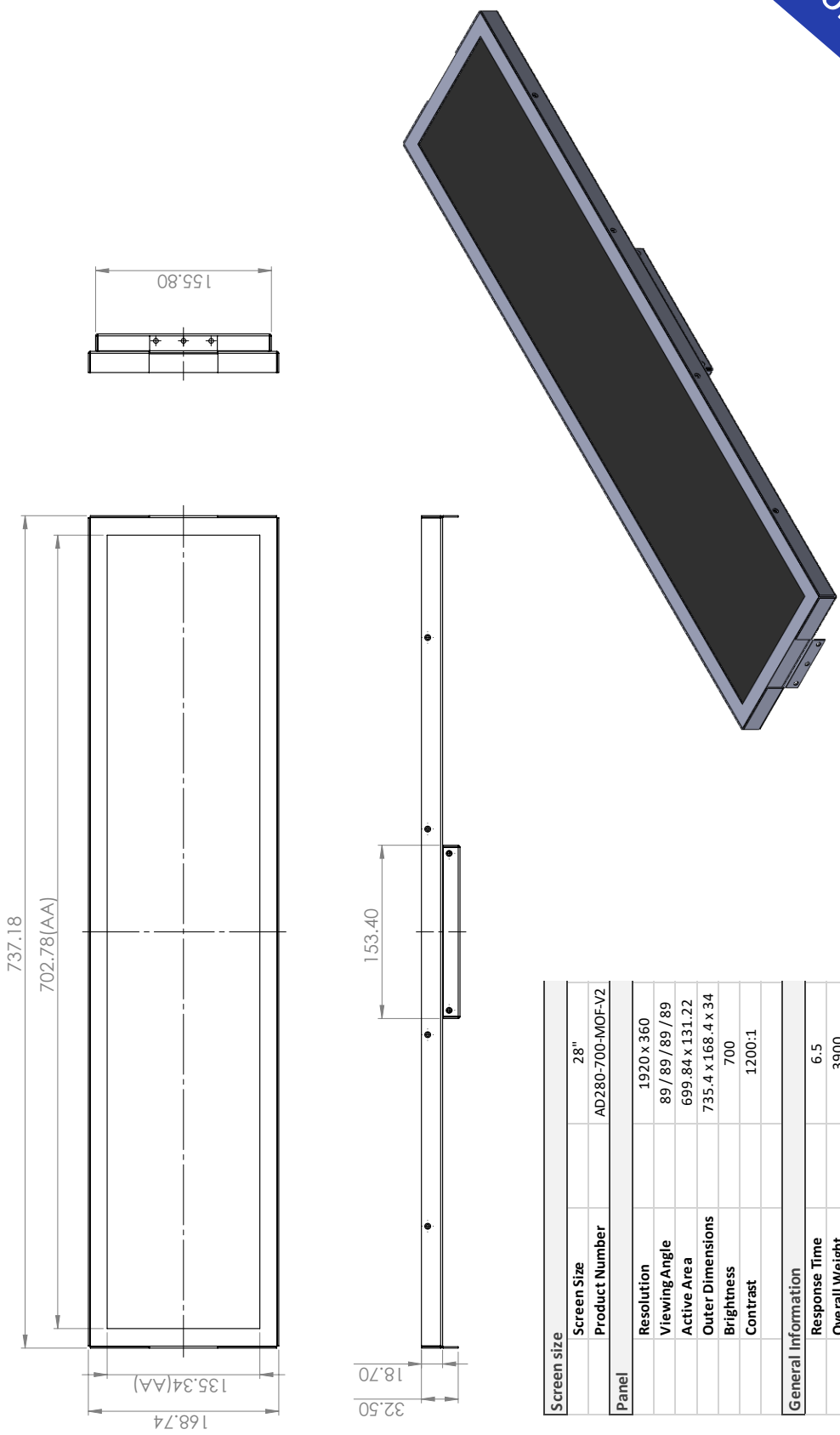

Screen size	28"
Product Number	AD280-700-MOF-V2
<b>Panel</b>	
Resolution	1920 x 360
Viewing Angle	89 / 89 / 89 / 89
Active Area	699.84 x 131.22
Outer Dimensions	735.4 x 168.4 x 34
Brightness	700
Contrast	1200:1
<b>General Information</b>	
Response Time	6.5
Overall Weight	3900
Operational Temp	0-50
Storage Temp	-20 - 60

\*Specifications are typical and subject to change.

# 36.6" Stretch Panel

Product Number – AD366-700-MOF-V2

Specifications

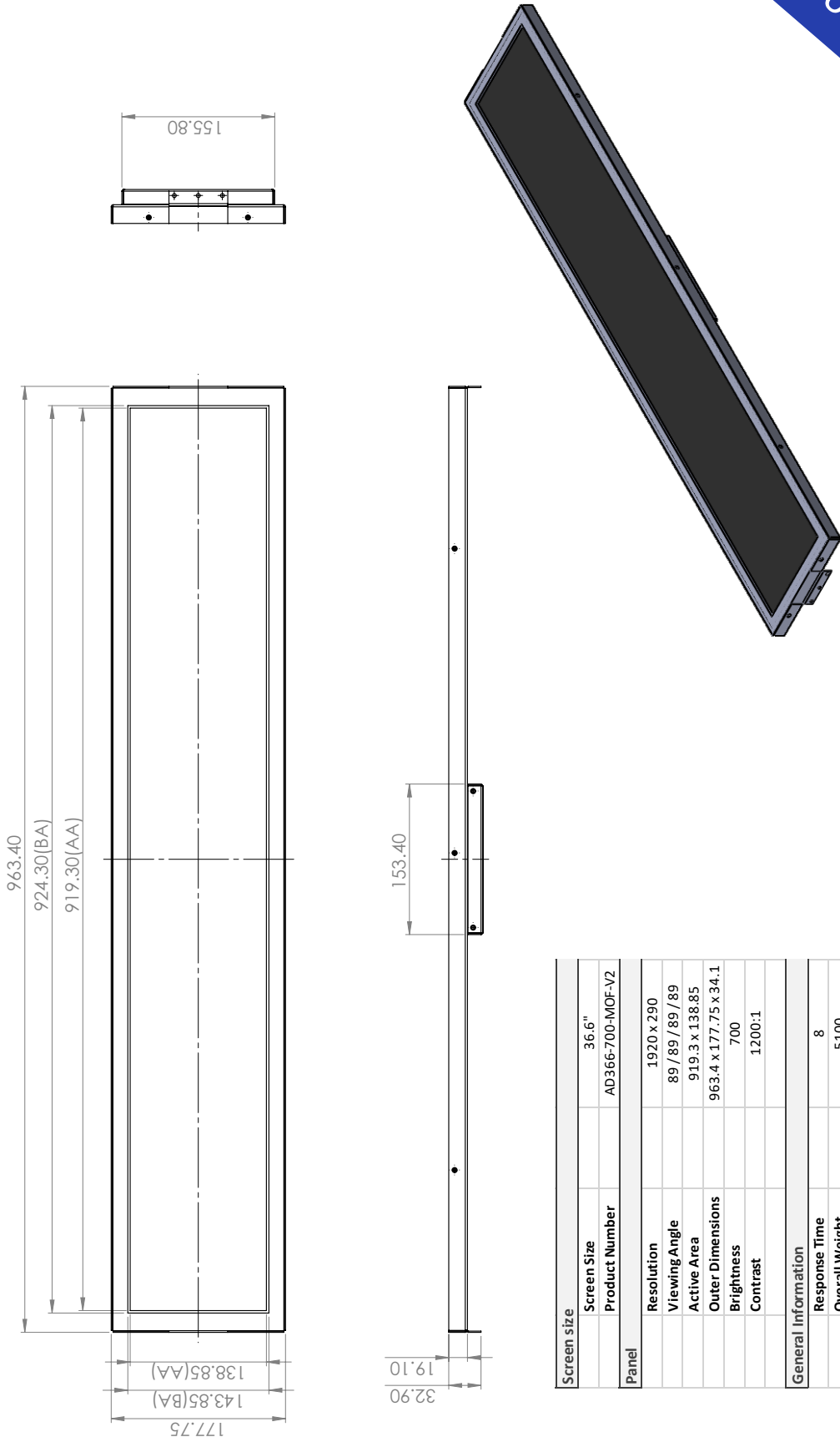

<b>Screen size</b>		36.6"
Screen Size	36.6"	
Product Number	AD366-700-MOF-V2	
<b>Panel</b>		
Resolution	1920 x 290	
Viewing Angle	89 / 89 / 89 / 89	
Active Area	919.3 x 138.85	
Outer Dimensions	963.4 x 177.75 x 34.1	
Brightness	700	
Contrast	1200:1	
<b>General Information</b>		
Response Time	8	
Overall Weight	5100	
Operational Temp	0-50	
Storage Temp	-20 - 60	

\*Specifications are typical and subject to change.

# 37" Stretch Panel

Product Number – AD370-700-MOF-V2

Specifications

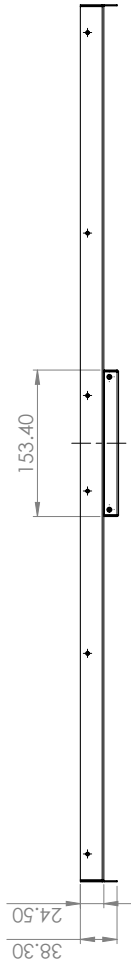
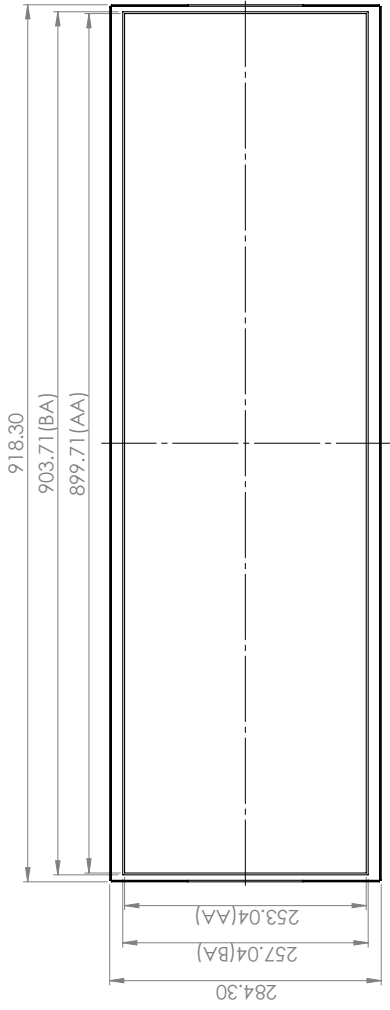
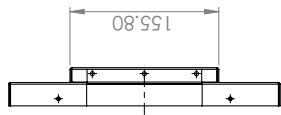
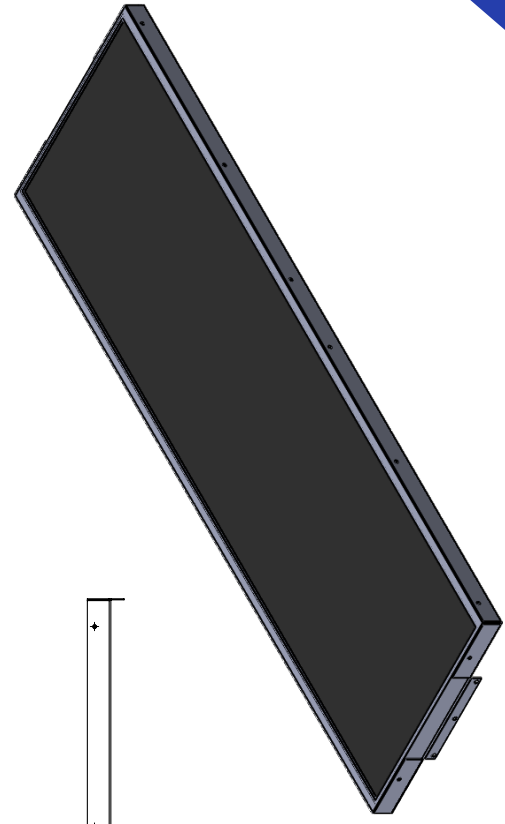

<b>Screen size</b>		Screen Size	37"
<b>Panel</b>		Product Number	AD370-700-MOF-V2
Resolution	1920 x 540		
Viewing Angle	89 / 89 / 89 / 89		
Active Area	899.712 x 253.044		
Outer Dimensions	918.3 x 284.3 x 40		
Brightness	700		
Contrast	1000:1		
<b>General Information</b>			
Response Time	14		
Overall Weight	7560		
Operational Temp	0-50		
Storage Temp	-20 - 60		

\*Specifications are typical and subject to change.



# 48" Stretch Panel



Specifications

Product Number – AD480-1000-MOF-V2

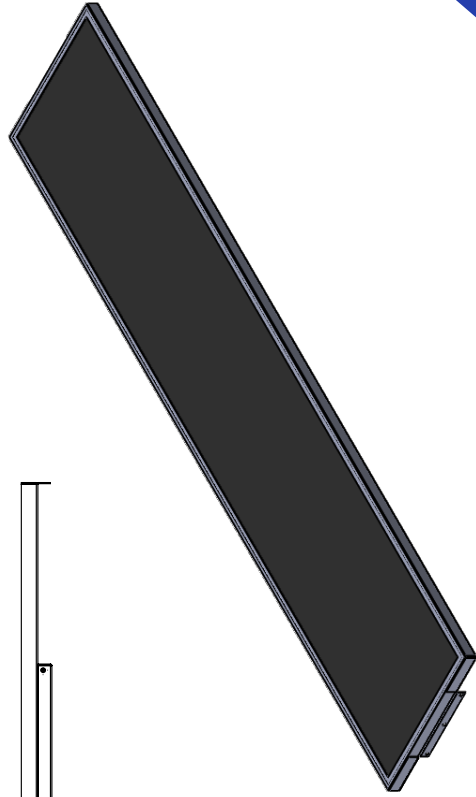
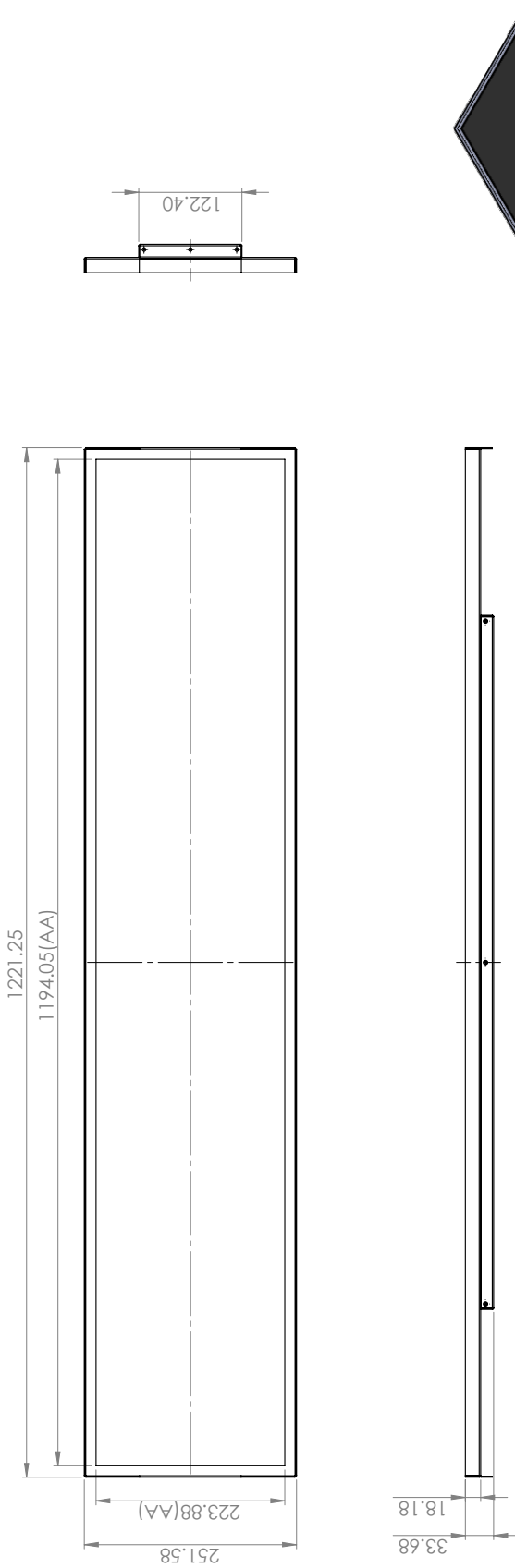

<b>Screen size</b>		48"
<b>Product Number</b>	AD480-1000-MOF-V2	
<b>Panel</b>		
<b>Resolution</b>	3840 x 720	
<b>Viewing Angle</b>	89 / 89 / 89 / 89	
<b>Active Area</b>	1194.05 x 223.88	
<b>Outer Dimensions</b>	1221.3 x 251.6 x 47.28	
<b>Brightness</b>	1000	
<b>Contrast</b>	1000:1	
<b>General Information</b>		
<b>Response Time</b>	10	
<b>Overall Weight</b>	5550	
<b>Operational Temp</b>	0-50	
<b>Storage Temp</b>	-20 - 60	

\*Specifications are typical and subject to change.