

Q-Tab Android Tablet Range

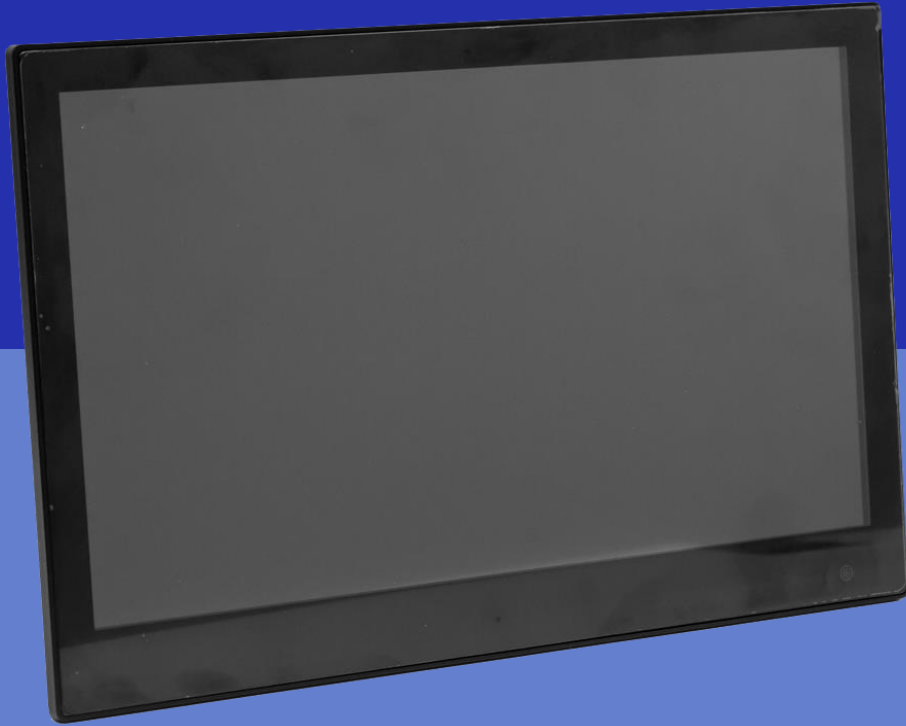

Commercial Grade Android tablets up to 55"
available with Rockchip 3288 & 3399



Wifi Enabled



Android 5 and 7

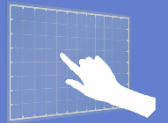

Capacitive Touch

Specifications

Q-Tab Android Tablet Range

Rockchip 3288 System	
Screen Size	14" – 55"
CPU	Quad core cortex A17, 1.8G, RK3288
Internal memory	16GB (upgrades available for volume orders)
Operating system	Android 5.1 (may vary on product from stock)
RAM	2GB

Rockchip 3399 System	
Screen Size	14" – 55"
CPU	Dual core A72 + quad core A53, 2.0G, RK3399
Internal memory	16GB (upgrades available for volume orders)
Operating system	Android 7
RAM	2GB

NETWORK			
Wifi	RK3288: 802.11b/g/n RK3399: 802.11b/g/n/ac 2.4G + 5G	3G dongle	3G USB dongle ext
Ethernet	10M/100M Ethernet	Bluetooth	Bluetooth 4.0

MEDIA SUPPORTED							
Video	MPEG-1,MPEG-2,MPEG-4,H.263,H.264,VC1,RV	RK3288: support up to 1080p	RK3399: support up to 4K	Image	Jpeg	Audio	MP3/WMA/AAC

*Specifications subject to change without notice

OVERVIEW

Low cost, professional tablets for deploying Android & apps. Touchscreen as standard. Also available with no touch

MARKETS

Our Android tablets are designed to address retail and commercial sector applications unmatched by consumer tablets – robust, highly reliable and in an unbeatable range of sizes. Two Rockchip versions cater for both simple and more complex apps

BENEFITS

- Compact & ruggedised
- Rockchip 3288 & 3399 Highly reliable, designed for 24/7 commercial use
- Auto-on



Specifications continued on the next page..

Q-Tab Android Tablet Range

INTERFACES												
Screen Size	14"	15.6"	17.3"	18.5"	21"	24"	27"	32"	43"	55"		
USB Host	3288: 3 x USB Host 2.0 3399: 3 x USB Host 3.0		3288: 2 x USB Host 2.0 3399: 2 x USB Host 3.0		3288: 3 x USB Host 2.0 3399: 3 x USB Host 3.0		3288: 2 x USB Host 2.0 3399: 2 x USB Host 3.0					
USB Device	Mini USB OTG											
Storage	SD, Support up to 32GB											
HDMI	HDMI output											
Power Jack	DC power input											
RJ45	Ethernet											
Earphone	3.5mm headphone											
DISPLAY SPECIFICATIONS												
Screen Size	14"	15.6"	17.3"	18.5"	21.5"	24"	27"	32"	43"	55"		
Resolution	1920x1080			1366x768		1920x1080						
Aspect	16:9											
Brightness	250 cd/m ²								300 cd/m ²			
Active Area mm	309.213 x 173.988	344.16 x 193.53	381.89 x 214.81	409.8 x 230.4	474.64 x 268.11	527.04 x 296.46	597.6 x 336.15	698.4 x 392.85	1094.96 diagonal	1387.8 diagonal		
Contrast	700:1	700:1	800:1	700:1	1000:1	1000:1	1000:1	3000:1	1200:1	1200:1		
View Angle	85° / 85° / 85° / 85°				89° / 89° / 89° / 89°							
OTHER												
Speakers	2 x 2W			2 x 3W				2 x 5W				
Camera	2.0M/P front				No camera				2 x 5W			
Touchscreen	10-point capacitive touch. Also available with no touch										G + G	
Mounting mm	100 x 100 wall mounting			75x75 Vesa	100 x 100 Vesa				400 x 400 Vesa			
Casing	Black plastic frame as standard											
Adaptor	12V 3A					12V 4A		12V 5A	AC100-240V			
Power						35W	40W	50W	100W	120W		
Dimensions mm	343x220x20	388x245x27	417x263x27	468x288x38	538x331x37	580x349x33	654x394x33	750x450x42	995x592x56	1263x747x57		
Weight kg	1.1	1.3	1.61	3.0	3.5	4.8	5.3	7.6	18			
Warranty	18 months			Certifications		As appropriate for country of deployment						

OVERVIEW

Low cost, professional tablets for deploying Android & apps. Touchscreen as standard. Also available with no touch

MARKETS

Our Android tablets are designed to address retail and commercial sector applications unmatched by consumer tablets – robust, highly reliable and in an unbeatable range of sizes. Two Rockchip versions cater for both simple and more complex apps

BENEFITS

- Compact & ruggedised
- Rockchip 3288 & 3399 Highly reliable, designed for 24/7 commercial use
- Auto-on



Capacitive Touch

Android 5 and 7

WiFi Enabled

14" AD Series Q-Tab

AD140PHA2; AD140PHA3; AD140PHA2-T; AD140PHA3-T

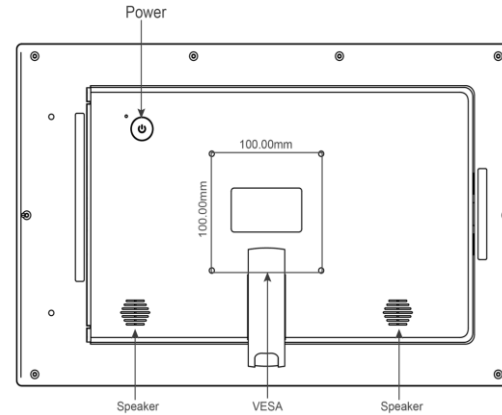
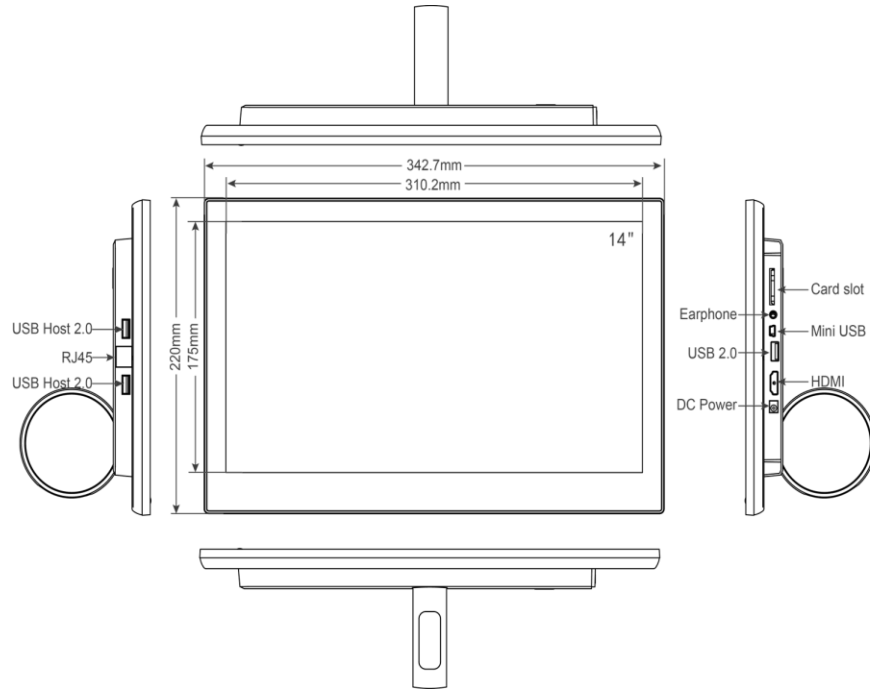

AD SERIES DISPLAYS MANUFACTURING LTD UNIT 4B, ELDON WAY INDUSTRIAL ESTATE, PADDOCK WOOD, TONBRIDGE, KENT, TN12 6BE TEL - 0870 0055 520 www.adseries.com	
PRODUCT CODE AD215PA	
PRODUCT NAME Q-TAB	
PRODUCT DESCRIPTION Q-TAB ALL-IN-ONE QUAD CORE ANDROID DISPLAY C/W ROCKCHIP CHIPSET.	
ALL DIMENSIONS SHOWN IN MILLIMETERS - UNLESS STATED OTHERWISE	THIRD ANGLE PROJECTION
THIS DRAWING IS THE PROPERTY OF AD SERIES DISPLAYS MANUFACTURING AND CONTAINS CONFIDENTIAL AND COPYRIGHT MATERIAL.	
NO PART OF THIS DRAWING MAY BE REPRODUCED OR TRANSMITTED IN ANY FORM OR BY ANY MEANS, ELECTRONIC OR MECHANICAL, FOR ANY PURPOSE, WITHOUT THE EXPRESS WRITTEN PERMISSION OF AD SERIES DISPLAYS MANUFACTURING.	
© 2015 AD SERIES DISPLAYS MANUFACTURING. ALL RIGHTS RESERVED	

*Specifications subject to change without notice

15.6" AD Series Q-Tab

AD156PHA2; AD156PHA3; AD156PHA2-T; AD156PH A3-T

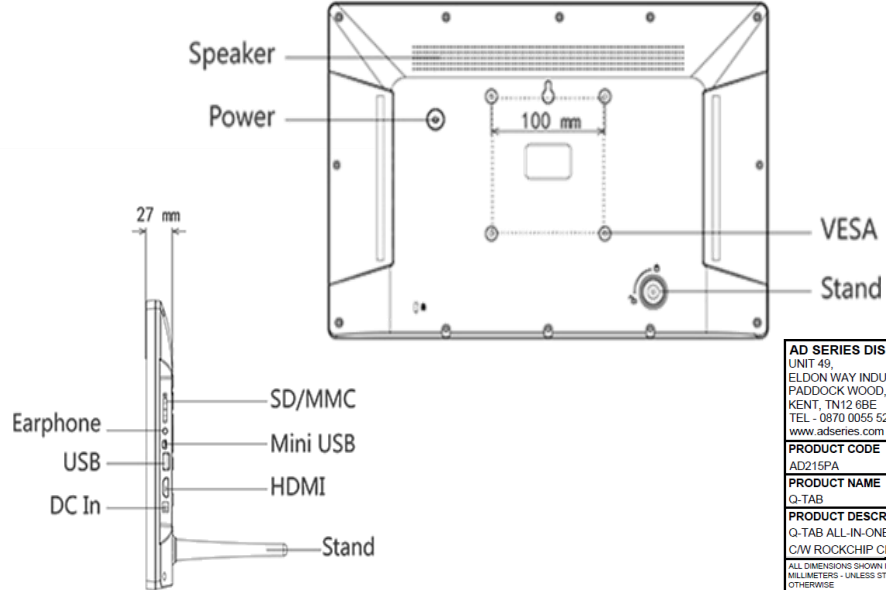
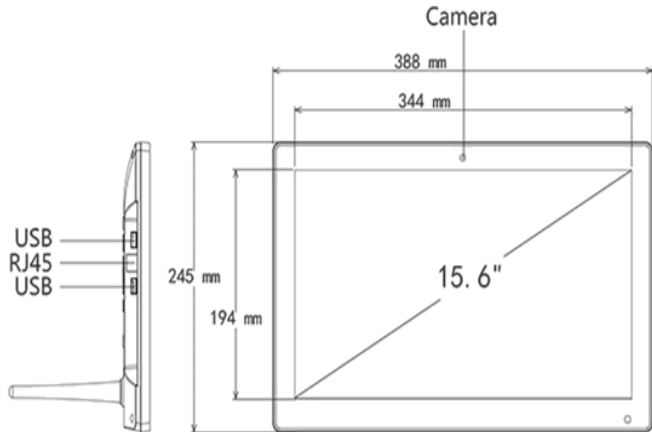

AD SERIES DISPLAYS MANUFACTURING LTD UNIT 48, ELDON WAY INDUSTRIAL ESTATE, PADDOCK WOOD, TONBRIDGE, KENT, TN12 6BE TEL - 0870 0055 520 www.adseries.com	
PRODUCT CODE	
AD215PA	
PRODUCT NAME	
Q-TAB	
PRODUCT DESCRIPTION	
Q-TAB ALL-IN-ONE QUAD CORE ANDROID DISPLAY C/W ROCKCHIP CHIPSET.	
<small>ALL DIMENSIONS SHOWN IN MILLIMETERS - UNLESS STATED OTHERWISE</small>	<small>THIRD ANGLE PROJECTION</small>
<small>THIS DRAWING IS THE PROPERTY OF AD SERIES DISPLAYS MANUFACTURING AND CONTAINS CONFIDENTIAL AND COPYRIGHT MATERIAL.</small>	
<small>NO PART OF THIS DRAWING MAY BE REPRODUCED OR TRANSMITTED IN ANY FORM OR BY ANY MEANS, ELECTRONIC OR MECHANICAL, FOR ANY PURPOSE, WITHOUT THE EXPRESS WRITTEN PERMISSION OF AD SERIES DISPLAYS MANUFACTURING.</small>	
<small>© 2015 AD SERIES DISPLAYS MANUFACTURING. ALL RIGHTS RESERVED</small>	

*Specifications subject to change without notice

17.3" AD Series Q-Tab

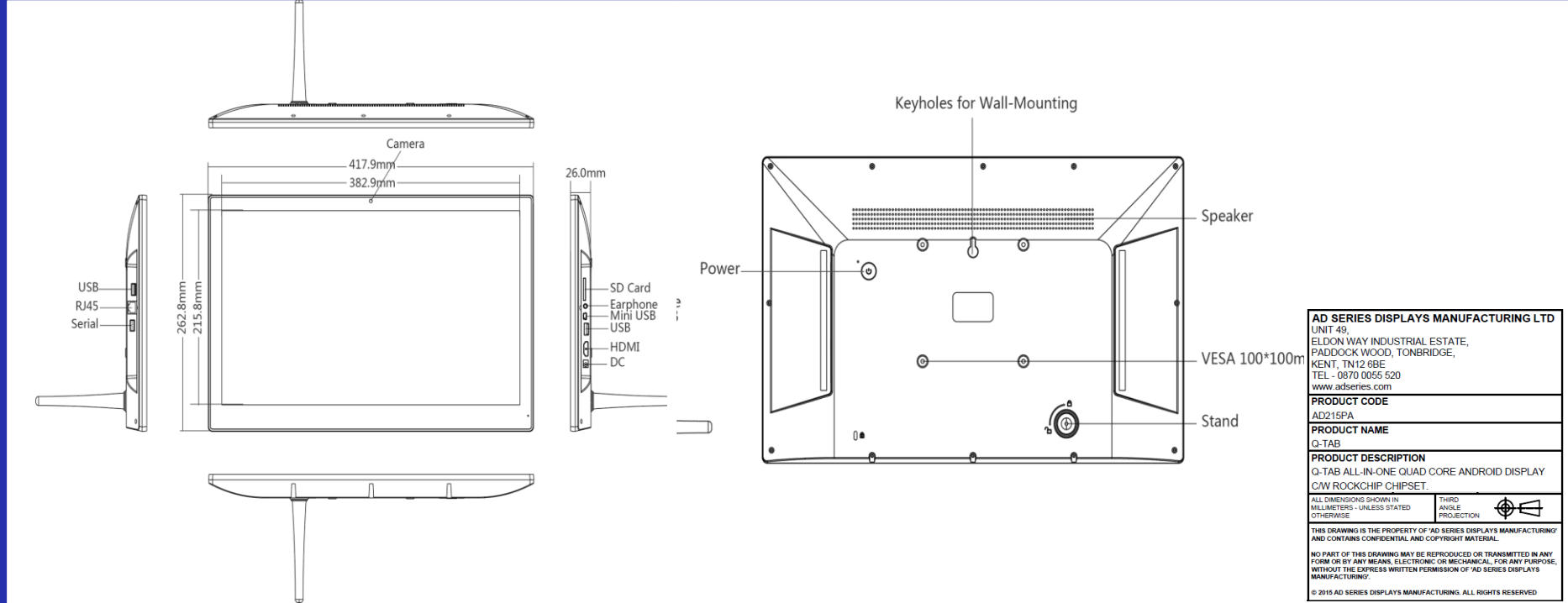

AD SERIES DISPLAYS MANUFACTURING LTD	
UNIT 48, ELDON WAY INDUSTRIAL ESTATE, PADDOCK WOOD, TONBRIDGE, KENT, TN12 6BE TEL - 0870 0055 520 www.adseries.com	
PRODUCT CODE AD215PA	
PRODUCT NAME Q-TAB	
PRODUCT DESCRIPTION Q-TAB ALL-IN-ONE QUAD CORE ANDROID DISPLAY C/W ROCKCHIP CHIPSET.	
ALL DIMENSIONS SHOWN IN MILLIMETERS - UNLESS STATED OTHERWISE	THIRD ANGLE PROJECTION
THIS DRAWING IS THE PROPERTY OF AD SERIES DISPLAYS MANUFACTURING AND CONTAINS CONFIDENTIAL AND COPYRIGHT MATERIAL.	
NO PART OF THIS DRAWING MAY BE REPRODUCED OR TRANSMITTED IN ANY FORM OR BY ANY MEANS, ELECTRONIC OR MECHANICAL, FOR ANY PURPOSE, WITHOUT THE EXPRESS WRITTEN PERMISSION OF AD SERIES DISPLAYS MANUFACTURING.	
© 2015 AD SERIES DISPLAYS MANUFACTURING. ALL RIGHTS RESERVED	

*Specifications subject to change without notice

18.5" AD Series Q-Tab

AD185PA2; AD185PA3; AD185PA2-T; AD185PA3-T

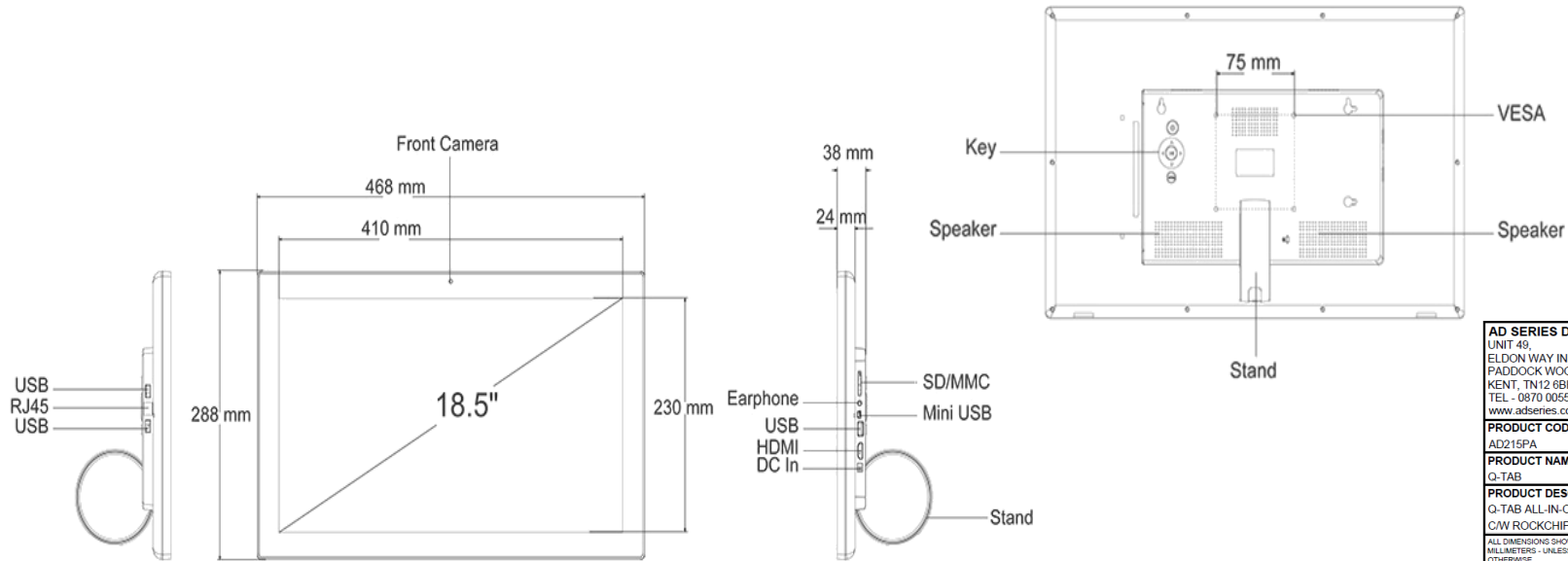

AD SERIES DISPLAYS MANUFACTURING LTD UNIT 48, ELDON WAY INDUSTRIAL ESTATE, PADDOCK WOOD, TONBRIDGE, KENT, TN12 6BE TEL - 0870 0055 520 www.adseries.com	
PRODUCT CODE AD215PA	
PRODUCT NAME Q-TAB	
PRODUCT DESCRIPTION Q-TAB ALL-IN-ONE QUAD CORE ANDROID DISPLAY C/W ROCKCHIP CHIPSET.	
ALL DIMENSIONS SHOWN IN MILLIMETERS - UNLESS STATED OTHERWISE	THIRD ANGLE PROJECTION
THIS DRAWING IS THE PROPERTY OF AD SERIES DISPLAYS MANUFACTURING AND CONTAINS CONFIDENTIAL AND COPYRIGHT MATERIAL.	
NO PART OF THIS DRAWING MAY BE REPRODUCED OR TRANSMITTED IN ANY FORM OR BY ANY MEANS, ELECTRONIC OR MECHANICAL, FOR ANY PURPOSE, WITHOUT THE EXPRESS WRITTEN PERMISSION OF AD SERIES DISPLAYS MANUFACTURING.	
© 2015 AD SERIES DISPLAYS MANUFACTURING. ALL RIGHTS RESERVED	

*Specifications subject to change without notice

Call Us: +44 (0)870 005 5520



21.5" AD Series Q-Tab

AD215PHA; AD215PHA2; AD215PHA-T; AD215PHA2-T

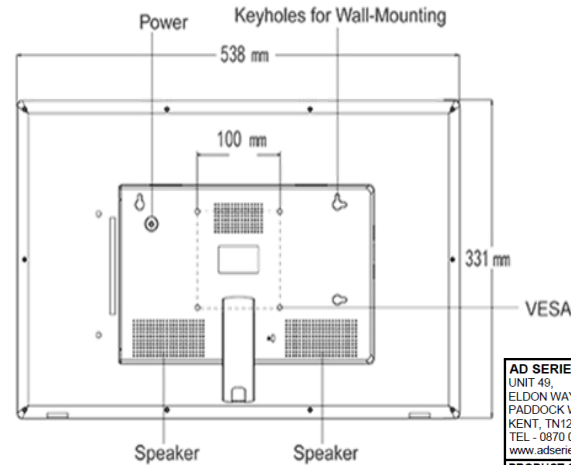
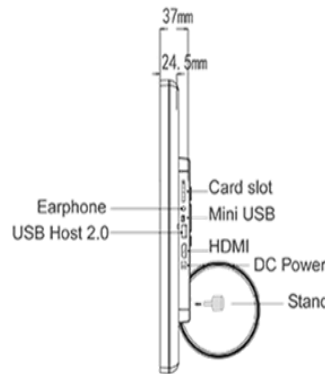
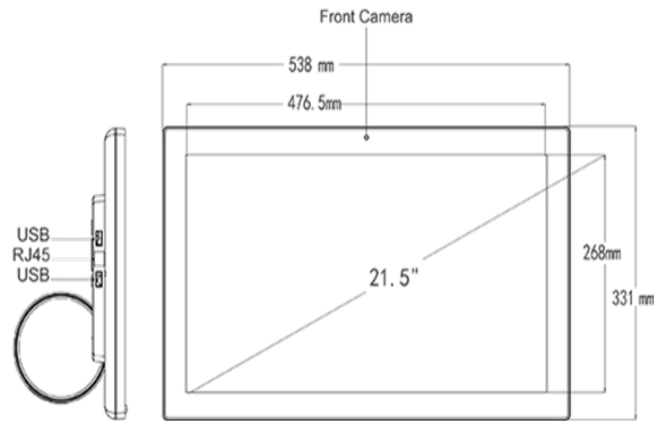

AD SERIES DISPLAYS MANUFACTURING LTD UNIT 48, ELDON WAY INDUSTRIAL ESTATE, PADDOCK WOOD, TONBRIDGE, KENT, TN12 6BE TEL - 0870 0055 520 www.adseries.com	
PRODUCT CODE	
AD215PA	
PRODUCT NAME	
Q-TAB	
PRODUCT DESCRIPTION	
Q-TAB ALL-IN-ONE QUAD CORE ANDROID DISPLAY C/W ROCKCHIP CHIPSET.	
ALL DIMENSIONS SHOWN IN MILLIMETERS - UNLESS STATED OTHERWISE	THIRD ANGLE PROJECTION
THIS DRAWING IS THE PROPERTY OF AD SERIES DISPLAYS MANUFACTURING AND CONTAINS CONFIDENTIAL AND COPYRIGHT MATERIAL.	
NO PART OF THIS DRAWING MAY BE REPRODUCED OR TRANSMITTED IN ANY FORM OR BY ANY MEANS, ELECTRONIC OR MECHANICAL, FOR ANY PURPOSE, WITHOUT THE EXPRESS WRITTEN PERMISSION OF AD SERIES DISPLAYS MANUFACTURING.	
© 2015 AD SERIES DISPLAYS MANUFACTURING. ALL RIGHTS RESERVED	

*Specifications subject to change without notice

24" AD Series Q-Tab

AD240PHA2; AD240PHA3; AD240PHA2-T; AD240
PHA3-T

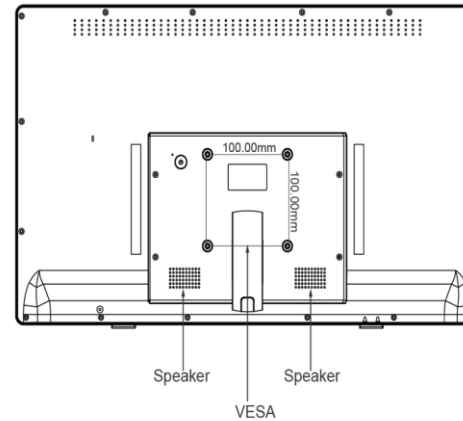
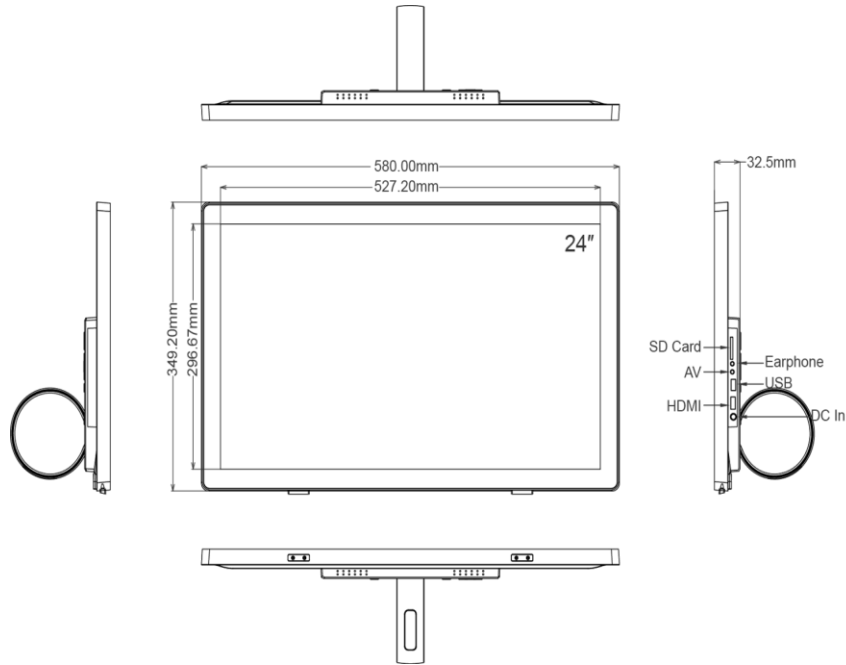

AD SERIES DISPLAYS MANUFACTURING LTD UNIT 48, ELDON WAY INDUSTRIAL ESTATE, PADDOCK WOOD, TONBRIDGE, KENT, TN12 6BE TEL - 0870 0055 520 www.adseries.com	
PRODUCT CODE AD215PA	
PRODUCT NAME Q-TAB	
PRODUCT DESCRIPTION Q-TAB ALL-IN-ONE QUAD CORE ANDROID DISPLAY C/W ROCKCHIP CHIPSET.	
ALL DIMENSIONS SHOWN IN MILLIMETERS - UNLESS STATED OTHERWISE	THIRD ANGLE PROJECTION
THIS DRAWING IS THE PROPERTY OF AD SERIES DISPLAYS MANUFACTURING AND CONTAINS CONFIDENTIAL AND COPYRIGHT MATERIAL.	
NO PART OF THIS DRAWING MAY BE REPRODUCED OR TRANSMITTED IN ANY FORM OR BY ANY MEANS, ELECTRONIC OR MECHANICAL, FOR ANY PURPOSE, WITHOUT THE EXPRESS WRITTEN PERMISSION OF AD SERIES DISPLAYS MANUFACTURING.	
© 2015 AD SERIES DISPLAYS MANUFACTURING. ALL RIGHTS RESERVED	

*Specifications subject to change without notice

27" AD Series Q-Tab

AD270PHA2; AD270PHA3; AD270PHA2-T; AD270PHA3-T

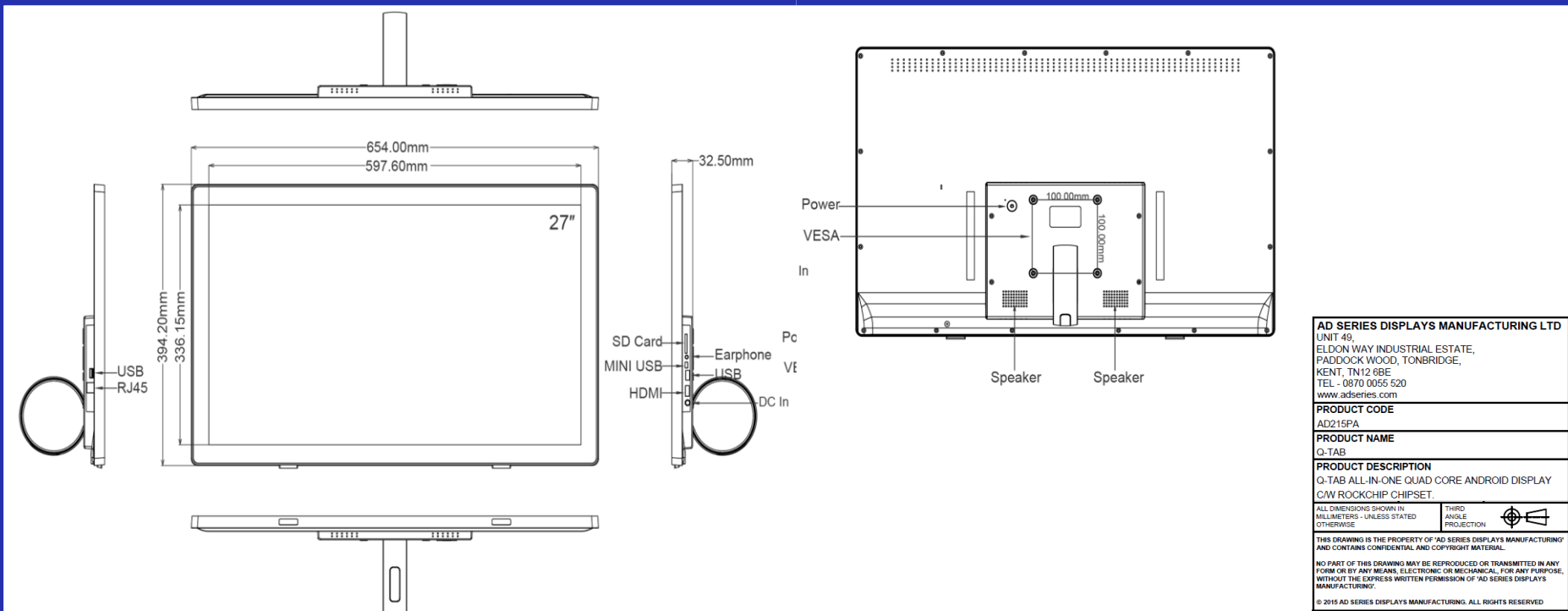

AD SERIES DISPLAYS MANUFACTURING LTD	
UNIT 48, ELDON WAY INDUSTRIAL ESTATE, PADDOCK WOOD, TONBRIDGE, KENT, TN12 6BE TEL - 0870 0055 520 www.adseries.com	
PRODUCT CODE	AD215PA
PRODUCT NAME	Q-TAB
PRODUCT DESCRIPTION	Q-TAB ALL-IN-ONE QUAD CORE ANDROID DISPLAY C/W ROCKCHIP CHIPSET.
ALL DIMENSIONS SHOWN IN MILLIMETERS - UNLESS STATED OTHERWISE	THIRD ANGLE PROJECTION
THIS DRAWING IS THE PROPERTY OF AD SERIES DISPLAYS MANUFACTURING AND CONTAINS CONFIDENTIAL AND COPYRIGHT MATERIAL.	
NO PART OF THIS DRAWING MAY BE REPRODUCED OR TRANSMITTED IN ANY FORM OR BY ANY MEANS, ELECTRONIC OR MECHANICAL, FOR ANY PURPOSE, WITHOUT THE EXPRESS WRITTEN PERMISSION OF AD SERIES DISPLAYS MANUFACTURING.	
© 2015 AD SERIES DISPLAYS MANUFACTURING. ALL RIGHTS RESERVED	

*Specifications subject to change without notice

Call Us: +44 (0)870 005 520



32" AD Series Q-Tab

AD320PHA2; AD320PHA3; AD320PHA2-T; AD320PHA3-T

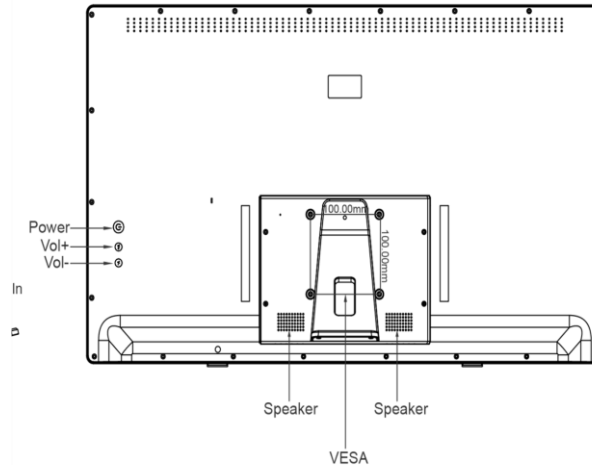
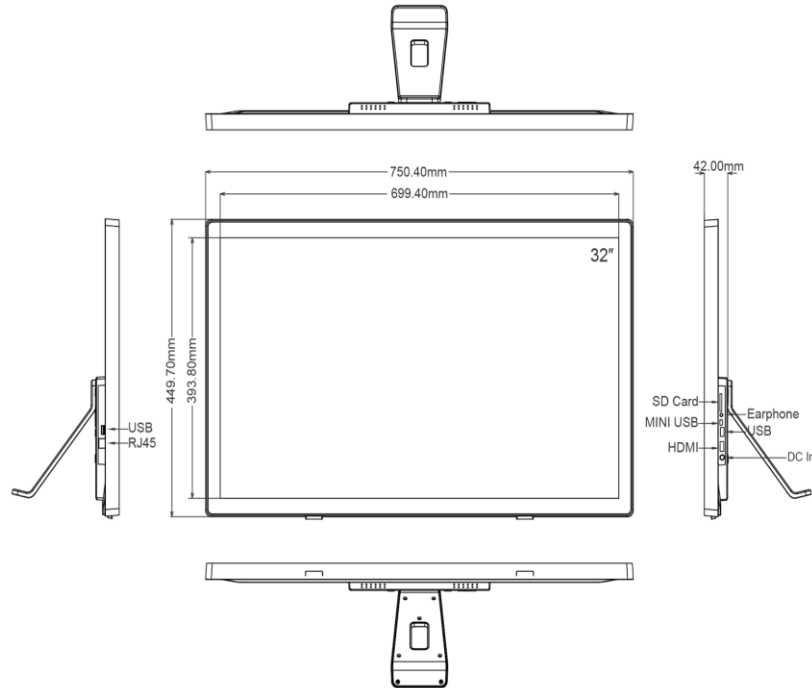

AD SERIES DISPLAYS MANUFACTURING LTD UNIT 48, ELDON WAY INDUSTRIAL ESTATE, PADDOCK WOOD, TONBRIDGE, KENT, TN12 6BE TEL - 0870 0055 520 www.adseries.com	
PRODUCT CODE	AD215PA
PRODUCT NAME	Q-TAB
PRODUCT DESCRIPTION	Q-TAB ALL-IN-ONE QUAD CORE ANDROID DISPLAY C/W ROCKCHIP CHIPSET.
ALL DIMENSIONS SHOWN IN MILLIMETERS - UNLESS STATED OTHERWISE	THIRD ANGLE PROJECTION
THIS DRAWING IS THE PROPERTY OF AD SERIES DISPLAYS MANUFACTURING AND CONTAINS CONFIDENTIAL AND COPYRIGHT MATERIAL.	
NO PART OF THIS DRAWING MAY BE REPRODUCED OR TRANSMITTED IN ANY FORM OR BY ANY MEANS, ELECTRONIC OR MECHANICAL, FOR ANY PURPOSE, WITHOUT THE EXPRESS WRITTEN PERMISSION OF AD SERIES DISPLAYS MANUFACTURING.	
© 2015 AD SERIES DISPLAYS MANUFACTURING. ALL RIGHTS RESERVED	

*Specifications subject to change without notice

Call Us: +44 (0)870 005 5

520



43" AD Series Q-Tab

AD430PHA2; AD430PHA2-T; AD430PHA3; AD430PHA3-T

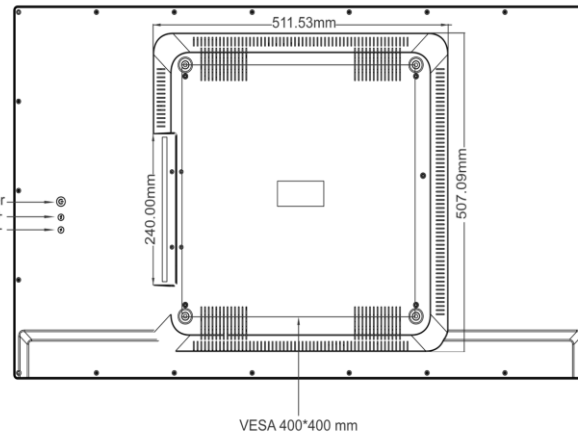
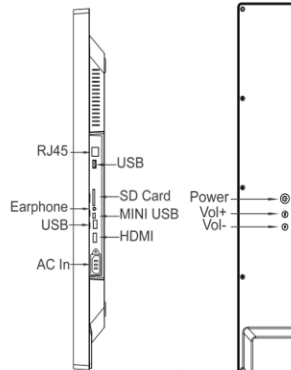
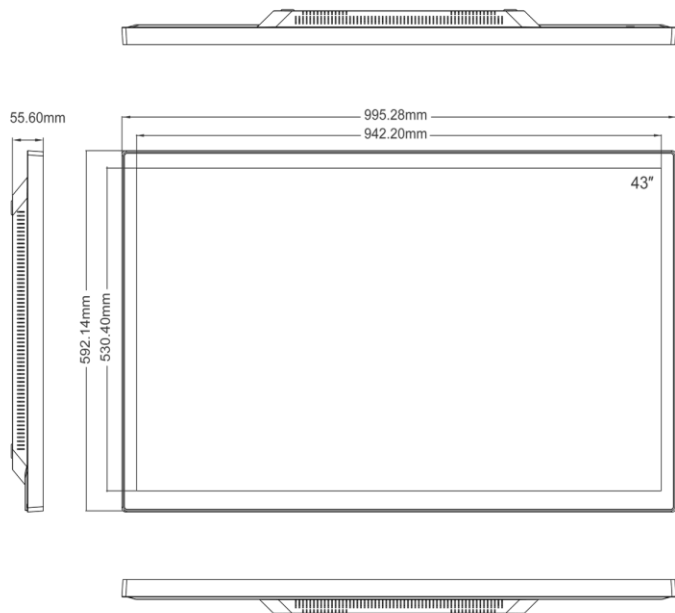

AD SERIES DISPLAYS MANUFACTURING LTD UNIT 48, ELDON WAY INDUSTRIAL ESTATE, PADDOCK WOOD, TONBRIDGE, KENT, TN12 6BE TEL - 0870 0055 520 www.adseries.com	
PRODUCT CODE	AD215PA
PRODUCT NAME	Q-TAB
PRODUCT DESCRIPTION	Q-TAB ALL-IN-ONE QUAD CORE ANDROID DISPLAY C/W ROCKCHIP CHIPSET.
ALL DIMENSIONS SHOWN IN MILLIMETERS - UNLESS STATED OTHERWISE	THIRD ANGLE PROJECTION
THIS DRAWING IS THE PROPERTY OF AD SERIES DISPLAYS MANUFACTURING AND CONTAINS CONFIDENTIAL AND COPYRIGHT MATERIAL.	
NO PART OF THIS DRAWING MAY BE REPRODUCED OR TRANSMITTED IN ANY FORM OR BY ANY MEANS, ELECTRONIC OR MECHANICAL, FOR ANY PURPOSE, WITHOUT THE EXPRESS WRITTEN PERMISSION OF AD SERIES DISPLAYS MANUFACTURING.	
© 2015 AD SERIES DISPLAYS MANUFACTURING. ALL RIGHTS RESERVED	

*Specifications subject to change without notice

Call Us: +44 (0)870 005 5520



55" AD Series Q-Tab

AD550PHA2; AD550PHA2-T; AD550PHA3; AD550
PHA3-T

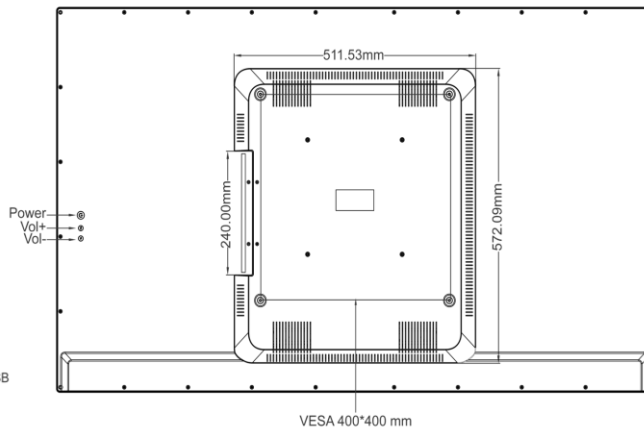
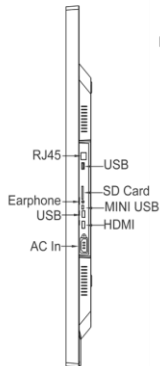
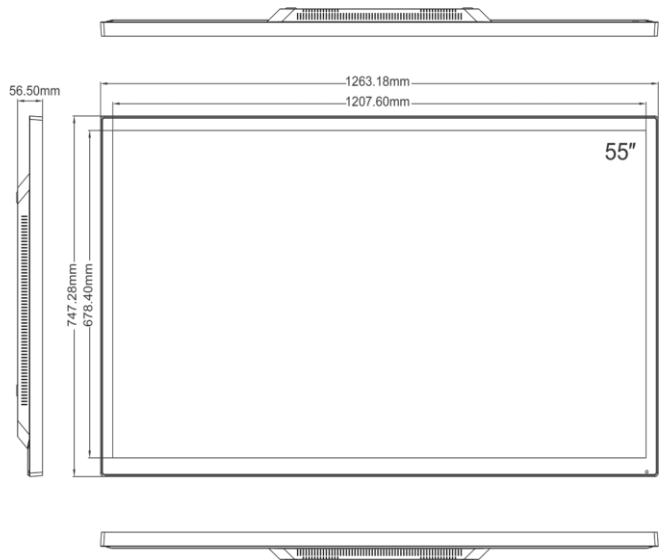

AD SERIES DISPLAYS MANUFACTURING LTD UNIT 48, ELDON WAY INDUSTRIAL ESTATE, PADDOCK WOOD, TONBRIDGE, KENT, TN12 6BE TEL - 0870 0055 520 www.adseries.com	
PRODUCT CODE AD215PA	
PRODUCT NAME Q-TAB	
PRODUCT DESCRIPTION Q-TAB ALL-IN-ONE QUAD CORE ANDROID DISPLAY C/W ROCKCHIP CHIPSET.	
ALL DIMENSIONS SHOWN IN MILLIMETERS - UNLESS STATED OTHERWISE	THIRD ANGLE PROJECTION
THIS DRAWING IS THE PROPERTY OF AD SERIES DISPLAYS MANUFACTURING AND CONTAINS CONFIDENTIAL AND COPYRIGHT MATERIAL.	
NO PART OF THIS DRAWING MAY BE REPRODUCED OR TRANSMITTED IN ANY FORM OR BY ANY MEANS, ELECTRONIC OR MECHANICAL, FOR ANY PURPOSE, WITHOUT THE EXPRESS WRITTEN PERMISSION OF AD SERIES DISPLAYS MANUFACTURING.	
© 2015 AD SERIES DISPLAYS MANUFACTURING. ALL RIGHTS RESERVED	

*Specifications subject to change without notice

Get in touch...



Call: [+44 \(0\)870 005 5520](tel:+44(0)8700055520)

Email: eva2@adseries.com