



Retail POS • Signage • Audio Visual • In-store • Events

Manufacturing Better By Design

www.adseries.com



Qplay Range

HD
1080p



AD Series Displays Manufacturing Ltd.



Call Us: [+44 \(0\)870 005 5520](tel:+4420870005520)

Email US: eva2@adseries.com

PRACTICAL, LOW COST - DISPLAYER/MONITORS - 10" – 55"



10" & 11.6"



14", 15.6" & 17.3"



18.5" & 21.5"



24"



as a **displayer**

- 1920 x 1080p HD playback*
- Memory card & USB storage
- Auto-on feature
- Fully integrated display with no peripherals
- Video, image & audio playback

as a **monitor**

- 1920 x 1080p HD
- Switch to HDMI input using remote control
- Simple easy-clean plastic casings
- Wide range of flexible mounting options



27"



32"



43" & 55"

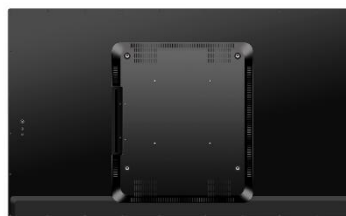

OVERVIEW

A comprehensive range of simple, straightforward and practical High Definition displays for low cost, effective signage.

Memory card operation for integrated content playback & HDMI for use as a monitor.

Fully enclosed plastic cases in black with flexible mounting options.

Designed for commercial operation with auto-on function at power up.

MARKETS

Retail & commercial signage
Promotions & campaigns
Gondola ends & FSDUs
Hospitality, Leisure & Heritage

KEY FEATURES

- No-frills operation for fast & simple deployment
- 1920 x 1080 High Definition (except 11.6" & 18.5")
- SD, MMC, MS card slot for use as a Displayer
- HDMI input for use as a Monitor



OEM available

HD
1080p



PRACTICAL, LOW COST - DISPLAYER/MONITORS - 10" – 55"

OPERATION

Playback	Auto playback and loop function for video files Automatic slide show playback Full function remote control		
Video formats	MPEG2, MPEG4, H.264, RM, RMVB, VC1, MPG, MOV, AVI, MKV, TS, M2TS .1920x1080p		
Audio formats	MP3, WMA	Image formats	JPEG
Power	Auto power ON/OFF	OSD language	Multi OSD language

INTERFACE

SD, MMC, MS Card slot	USB Host 2.0
AV (CVBS + audio).	HDMI input
3.5mm earphone	DC 12V power

SCREEN & MECHANICAL

Product Code	LAD101P-E	LAD116P-E	LADHD140P	LADHD156P	LADHD1P	LAD185P	LADHD215P	LADHD240P
Screen Size	10.1"	11.6"	14"	15.6"	17.3"	18.5"	21.5"	24"
Active Area mm	216.56 x 135.36	256.32 x 144.18		344.16 x 193.59	381.89 x 214.81	409.8 x 230.4	474.64 x 268.11	527.04 x 296.46
Resolution	1280x800	1920x1080			1366x768		1920x1080	
Aspect Ratio	16:9	16:9	16:9	16:9	16:9	16:9	16:9	16:9
Brightness cd/m ²	450	300	300	300	250	250	250	250
Contrast Ratio	900:1	800:1	700:1	700:1	800:1	1000:1	1000:1	1000:1
Viewing Angle HxV	178 X 178	178 x 178	160 x 160	170 X 170	170 x 170	178 x 178	178 x 178	
Mounting	75 x 75mm Vesa	75 x 75mm Vesa	100 x 100 mm Vesa plus keyhole hanging			75 x 75 Vesa + keyhole	100 x 100mm wall mounting	
Casing	Black plastic frame as standard							
Speakers	2 x 1W		2 x 2W			2 x 3W		2 x 3W
Adaptor	5V 2A	12V 2A	12V 3A					12V 5A
Power consumption	10W	12W	15W	18W	20W	25W	30W	35W
Dimensions mm	247 x 170 x 20.7	284 x 182 x 29	343 x 220 x 25	388 x 245 x 27	418 x 263 x 27	468 x 288 x 37.5	538 x 331 x 37	580 x 349 x 32.5
Weight kg	0.5	0.6	1.0	1.2	1.3	3.0	3.6	4.8

OVERVIEW

A comprehensive range of simple, straightforward and practical High Definition displays for low cost, effective signage.

Memory card operation for integrated content playback & HDMI for use as a monitor.

Fully enclosed plastic cases in black with flexible mounting options.

Designed for commercial operation with auto-on function at power up.

MARKETS

Retail & commercial signage
Promotions & campaigns
Gondola ends & FSDUs
Hospitality, Leisure & Heritage

KEY FEATURES

- No-frills operation for fast & simple deployment
- 1920 x 1080 High Definition (except 11.6" & 18.5")
- SD, MMC, MS card slot for use as a Displayer
- HDMI input for use as a Monitor



OEM available

HD
1080p



PRACTICAL, LOW COST - DISPLAYER/MONITORS - 10" – 55"

OPERATION

Playback	Auto playback and loop function for video files Automatic slide show playback Full function remote control		
Video formats	MPEG2, MPEG4, H.264, RM, RMVB, VC1, MPG, MOV, AVI, MKV, TS, M2TS .1920x1080p		
Audio formats	MP3, WMA	Image formats	JPEG
Power	Auto power ON/OFF	OSD language	Multi OSD language

INTERFACE

SD, MMC, MS Card slot	USB Host 2.0
AV (CVBS + audio).	HDMI input
3.5mm earphone	DC 12V power

SCREEN & MECHANICAL

Product Code	LADHD270P	LADHD320P	LADHD430P	LADHD550P
Screen Size	27"	32"	43"	55"
Active Area mm	597.6 x 336.15	698.4 x 392.88	1094.96 diagonal	1209.6 x 681.4
Resolution	1920x1080			
Aspect Ratio	16:9			
Brightness cd/m ²	300	250	300	300
Contrast Ratio	1000:1	3000:1	1200:1	4000:1
Viewing Angle HxV	178 X 178			
Mounting	100 x 100 mm wall mounting			
Casing	Black plastic frame as standard			
Speakers	2 x 3W		2 x 5W	
Adaptor	AC 100-240V			
Power consumption	40W	50W	100W	120W
Dimensions mm	654 x 394 x 72.5	750 x 450 x 42	995 x 592 x 55.6	1263x747x57
Weight kg	5.2	7.6	18	

OVERVIEW

A comprehensive range of simple, straightforward and practical High Definition displays for low cost, effective signage.

Memory card operation for integrated content playback & HDMI for use as a monitor.

Fully enclosed plastic cases in black with flexible mounting options.

Designed for commercial operation with auto-on function at power up.

MARKETS

Retail & commercial signage
Promotions & campaigns
Gondola ends & FSDUs
Hospitality, Leisure & Heritage

KEY FEATURES

- No-frills operation for fast & simple deployment
- 1920 x 1080 High Definition (except 11.6" & 18.5")
- SD, MMC, MS card slot for use as a Displayer
- HDMI input for use as a Monitor



Technical Drawings

TECHNICAL DRAWINGS INDEX – AD SERIES QTAB 10” – 55”

Screen Size	Resolution	Page number
10.1”	1280 x 800	<u>6</u>
11.6”	1920 x 1080 HD	<u>7</u>
14”	1920 x 1080 HD	<u>8</u>
15.6”	1920 x 1080 HD	<u>9</u>
17.3”	1920 x 1080 HD	<u>10</u>
18.5”	1366 x 768	<u>11</u>
21.5”	1920 x 1080 HD	<u>12</u>
24”	1920 x 1080 HD	<u>13</u>
27”	1920 x 1080 HD	<u>14</u>
32”	1920 x 1080 HD	<u>15</u>
43”	1920 x 1080 HD	<u>16</u>
55”	1920 x 1080 HD	<u>17</u>

10.1" QPLAY LAD101P-E

This model has a flush glass front panel
Also available without

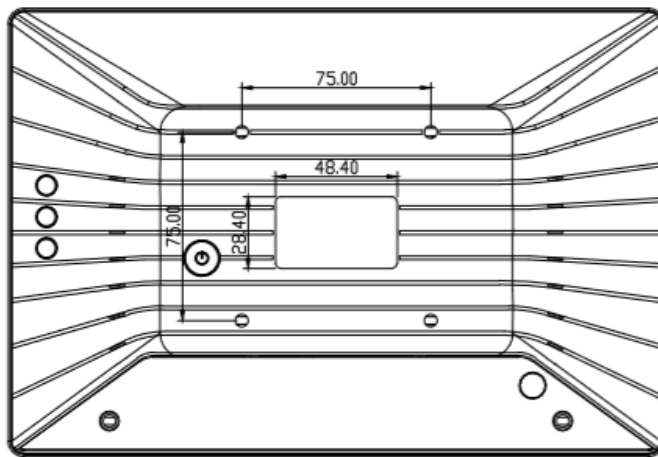
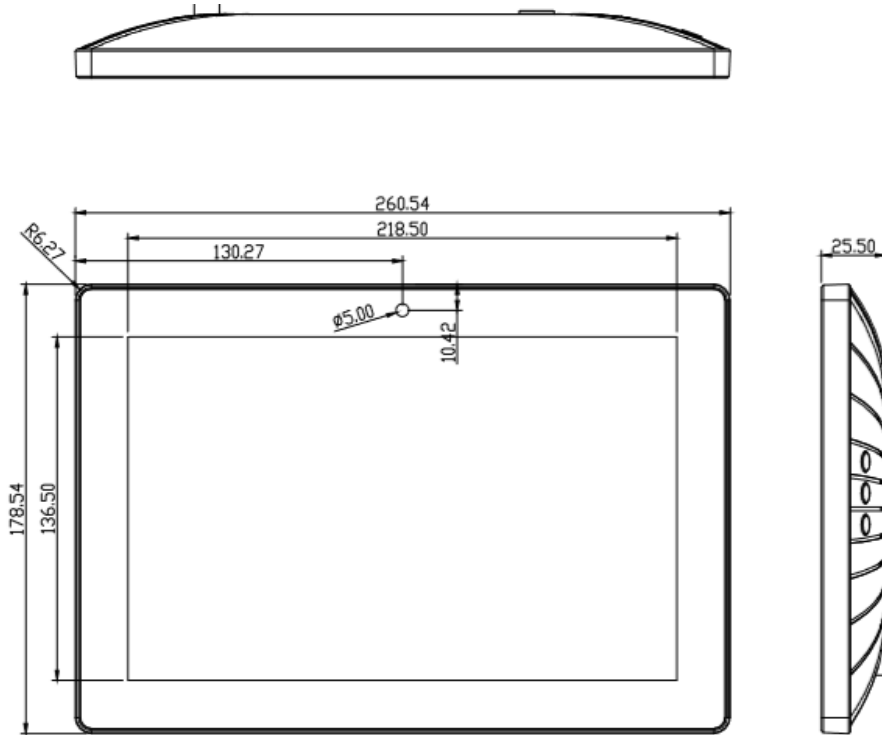

AD SERIES DISPLAYS MANUFACTURING LTD UNIT 49, ELDON WAY INDUSTRIAL ESTATE, PADDOCK WOOD, TONBRIDGE, KENT, TN12 6BE TEL - 0870 0055 520 www.adseries.com	
PRODUCT CODE LADHD101P	
PRODUCT NAME Q-TAB	
PRODUCT DESCRIPTION QPLAY HD DISPLAYER WITH HDMI	
ALL DIMENSIONS SHOWN IN MILLIMETERS - UNLESS STATED OTHERWISE	THIRD ANGLE PROJECTION
THIS DRAWING IS THE PROPERTY OF 'AD SERIES DISPLAYS MANUFACTURING' AND CONTAINS CONFIDENTIAL AND COPYRIGHT MATERIAL. NO PART OF THIS DRAWING MAY BE REPRODUCED OR TRANSMITTED IN ANY FORM OR BY ANY MEANS, ELECTRONIC OR MECHANICAL, FOR ANY PURPOSE, WITHOUT THE EXPRESS WRITTEN PERMISSION OF 'AD SERIES DISPLAYS MANUFACTURING'. © 2018 AD SERIES DISPLAYS MANUFACTURING ALL RIGHTS RESERVED	

11.6" QPLAY LAD116P-E

This model has a flush glass front panel
Also available without

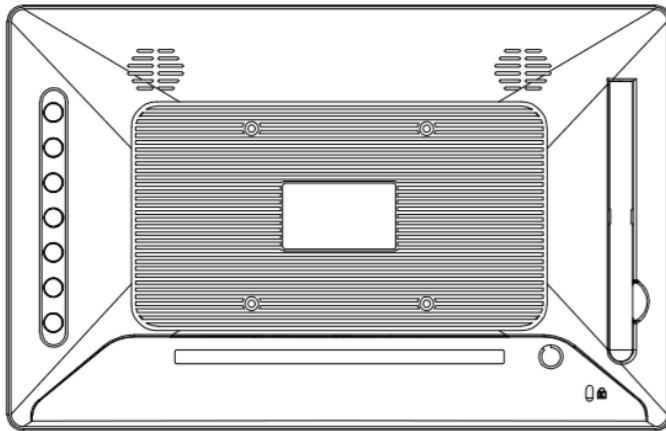
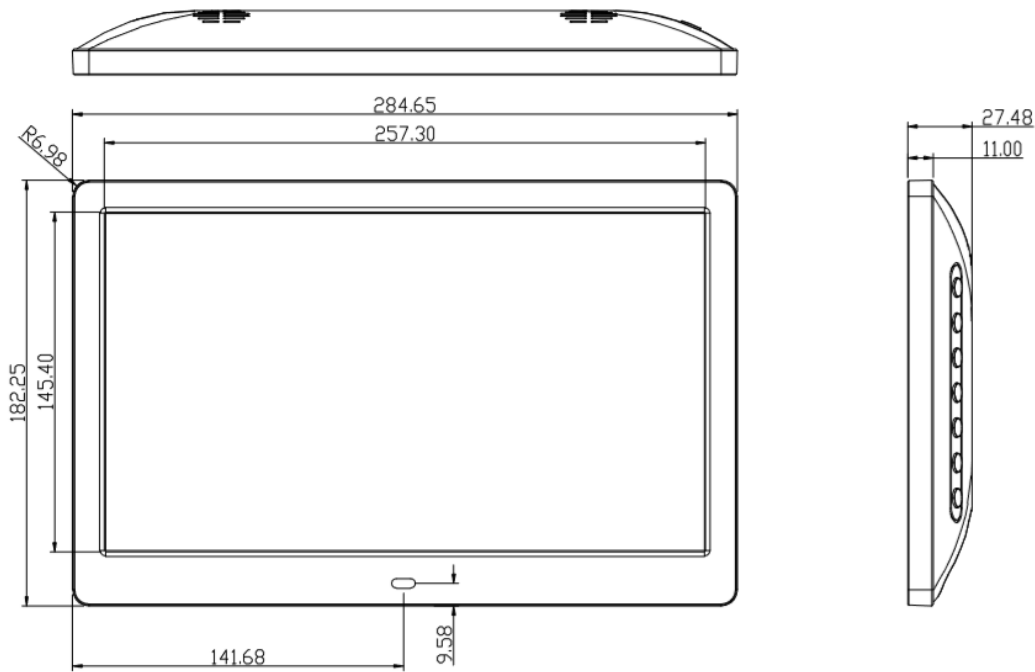

AD SERIES DISPLAYS MANUFACTURING LTD UNIT 49, ELDON WAY INDUSTRIAL ESTATE, PADDOCK WOOD, TONBRIDGE, KENT, TN12 6BE TEL - 0870 0055 520 www.adseries.com	
PRODUCT CODE LAD116P	
PRODUCT NAME Q-TAB	
PRODUCT DESCRIPTION QPLAY HD DISPLAYER WITH HDMI	
ALL DIMENSIONS SHOWN IN MILLIMETERS - UNLESS STATED OTHERWISE	THIRD ANGLE PROJECTION
© 2018 AD SERIES DISPLAYS MANUFACTURING. DISPLAYS MANUFACTURING AND CONTAINS CONFIDENTIAL AND COPYRIGHT MATERIAL.	
NO PART OF THIS DRAWING MAY BE REPRODUCED OR TRANSMITTED IN ANY FORM OR BY ANY MEANS, ELECTRONIC OR MECHANICAL, FOR ANY PURPOSE, WITHOUT THE EXPRESS WRITTEN PERMISSION OF AD SERIES DISPLAYS MANUFACTURING.	
©2018 AD SERIES DISPLAYS MANUFACTURING ALL RIGHTS RESERVED	

14" QPLAY LADHD140P

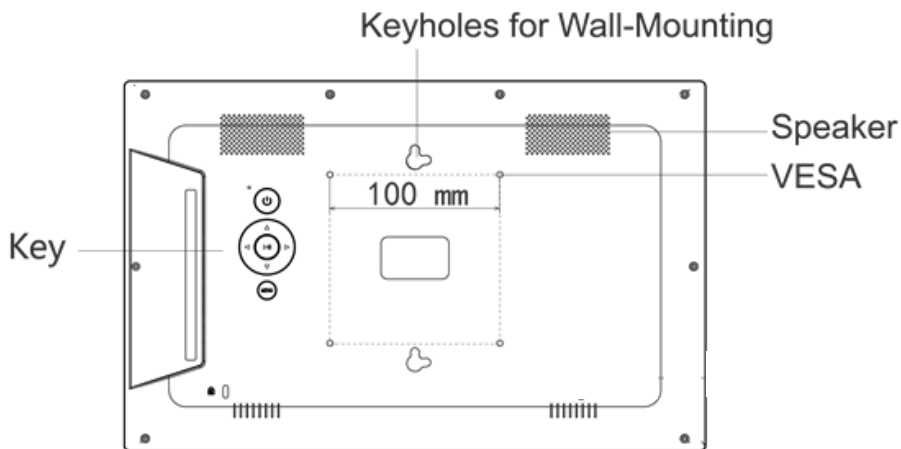
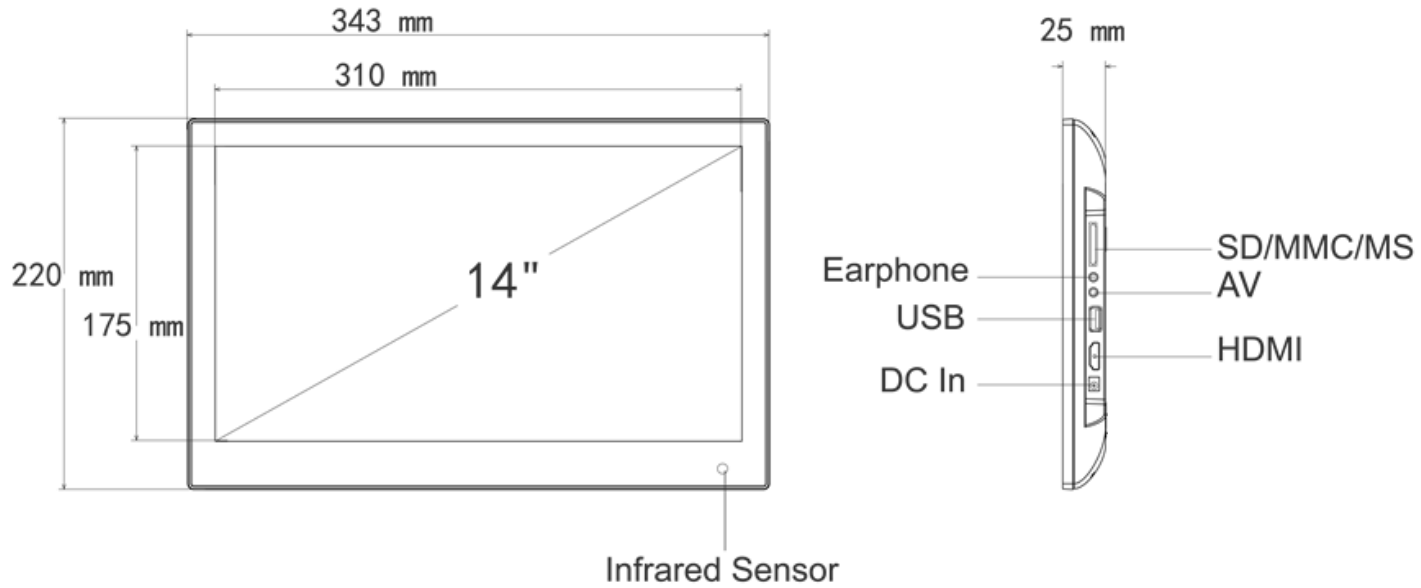

AD SERIES DISPLAYS MANUFACTURING LTD UNIT 49, ELDDON WAY INDUSTRIAL ESTATE, PADDOCK WOOD, TONBRIDGE, KENT, TN12 6BE, TEL - 0870 0055 520 www.adseries.com	
PRODUCT CODE LADHD140P	
PRODUCT NAME Qplay	
PRODUCT DESCRIPTION QPLAY HD DISPLAYER WITH HDMI	
ALL DIMENSIONS SHOWN IN MILLIMETERS - UNLESS STATED OTHERWISE	THIRD ANGLE PROJECTION
<small>THIS DRAWING IS THE PROPERTY OF AD-SERIES DISPLAYS MANUFACTURING AND CONTAINS CONFIDENTIAL AND COPYRIGHT MATERIAL. ©2018 AD-SERIES DISPLAYS MANUFACTURING LTD OR TRANSMITTED IN ANY FORM OR BY ANY MEANS, ELECTRONIC OR MECHANICAL, FOR ANY PURPOSE, WITHOUT THE EXPRESS WRITTEN PERMISSION OF AD-SERIES DISPLAYS MANUFACTURING. ©2018 AD-SERIES DISPLAYS MANUFACTURING ALL RIGHTS RESERVED</small>	

15.6" QPLAY LADHD156P

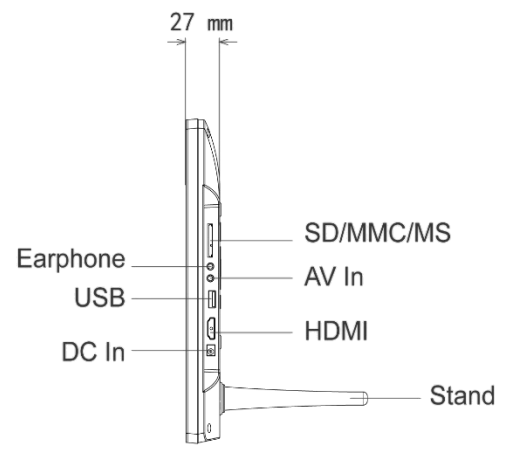
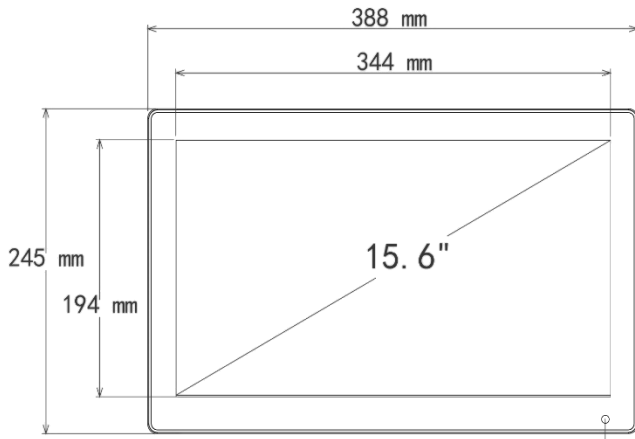

Infrared Sensor
Keyholes for Wall-Mounting

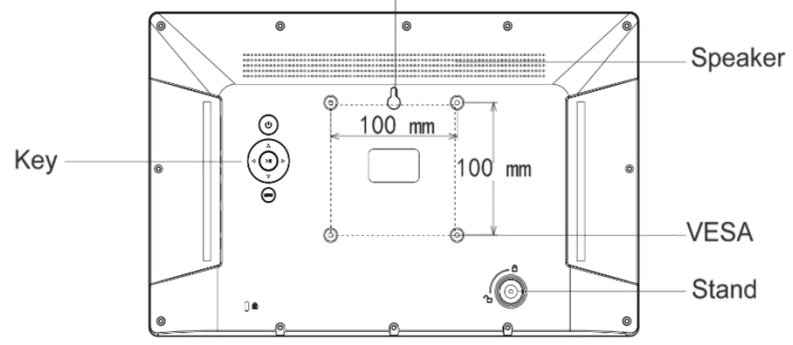

AD SERIES DISPLAYS MANUFACTURING LTD UNIT 49, ELDON WAY INDUSTRIAL ESTATE, PADDOCK WOOD, TONBRIDGE, KENT, TN12 6BE TEL - 0870 0055 520 www.adseries.com	
PRODUCT CODE LADHD156P	
PRODUCT NAME Qplay	
PRODUCT DESCRIPTION QPLAY HD DISPLAYER WITH HDMI	
ALL DIMENSIONS SHOWN IN MILLIMETERS - UNLESS STATED OTHERWISE	THIRD ANGLE PROJECTION
THIS DRAWING IS THE PROPERTY OF AD SERIES DISPLAYS MANUFACTURING AND CONTAINS CONFIDENTIAL AND COPYRIGHT MATERIAL. NO PART OF THIS DRAWING MAY BE REPRODUCED OR TRANSMITTED IN ANY FORM OR BY ANY MEANS, ELECTRONIC OR MECHANICAL, FOR ANY PURPOSE, WITHOUT THE EXPRESS WRITTEN PERMISSION OF AD SERIES DISPLAYS MANUFACTURING. © 2018 AD SERIES DISPLAYS MANUFACTURING ALL RIGHTS RESERVED	

17.3" QPLAY LAD173P

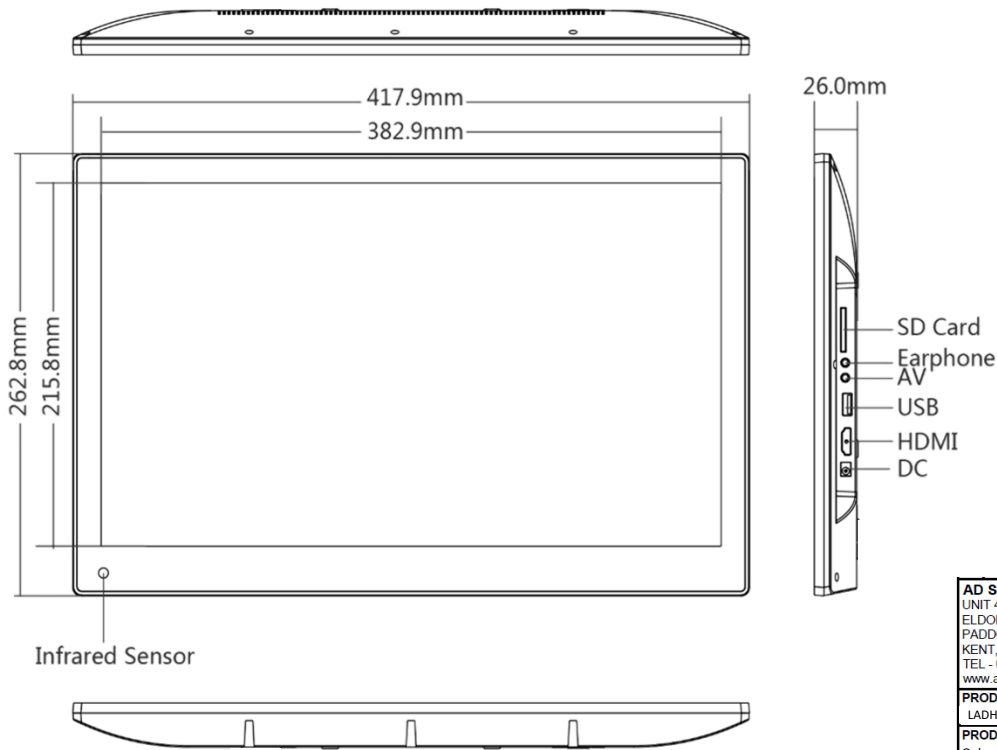

Infrared Sensor

AD SERIES DISPLAYS MANUFACTURING LTD UNIT 49, ELDON WAY INDUSTRIAL ESTATE, PADDOCK WOOD, TONBRIDGE, KENT, TN12 6BE TEL - 0870 0055 520 www.adseries.com		
PRODUCT CODE LADHD173P		
PRODUCT NAME Qplay		
PRODUCT DESCRIPTION QPLAY HD DISPLAYER WITH HDMI		
DRAWING NUMBER AD0002-01		
DRAWN BY RP	APPROVED BY MB	DATE Dec 2017
REV -	SCALE 1:5 @ A4	SHEET NO. 1 OF 1
ALL DIMENSIONS SHOWN IN MILLIMETERS - UNLESS STATED OTHERWISE		THIRD ANGLE PROJECTION
THIS DRAWING IS THE PROPERTY OF 'AD SERIES DISPLAYS MANUFACTURING' AND CONTAINS CONFIDENTIAL AND COPYRIGHT MATERIAL.		
NO PART OF THIS DRAWING MAY BE REPRODUCED OR TRANSMITTED IN ANY FORM OR BY ANY MEANS, ELECTRONIC OR MECHANICAL, FOR ANY PURPOSE, WITHOUT THE EXPRESS WRITTEN PERMISSION OF 'AD SERIES DISPLAYS MANUFACTURING'.		
© 2018 AD SERIES DISPLAYS MANUFACTURING ALL RIGHTS RESERVED		

Keyholes for Wall-Mounting

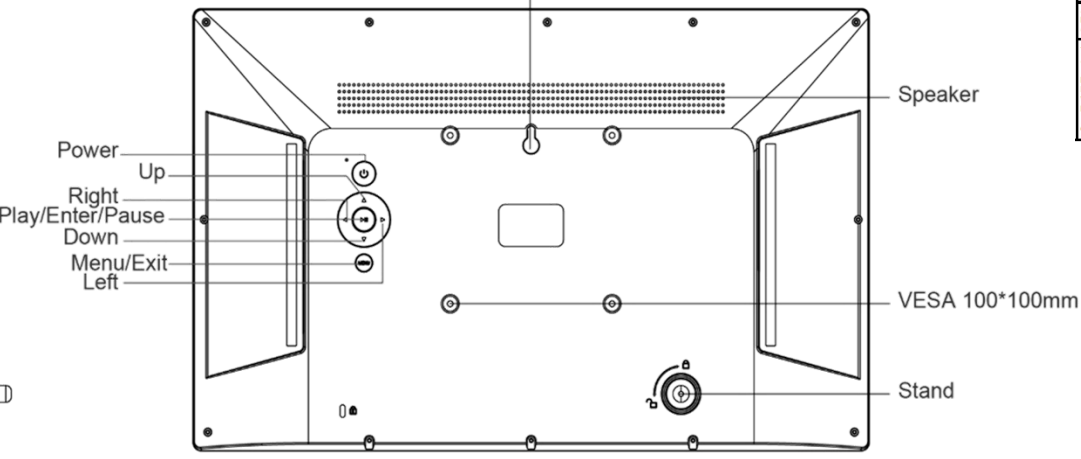

Speaker

VESA 100*100mm

Stand

2018 AD SERIES DISPLAYS MANUFACTURING

18.5" QPLAY LADHD185P

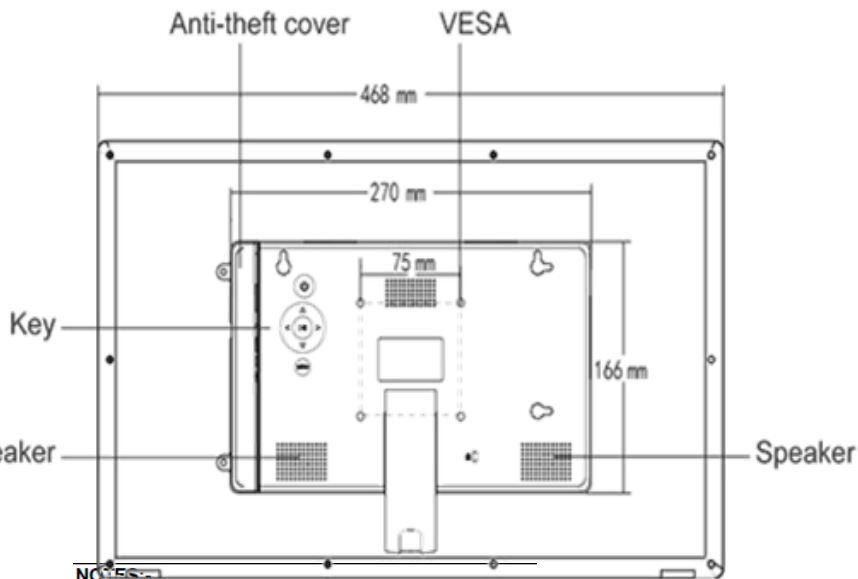
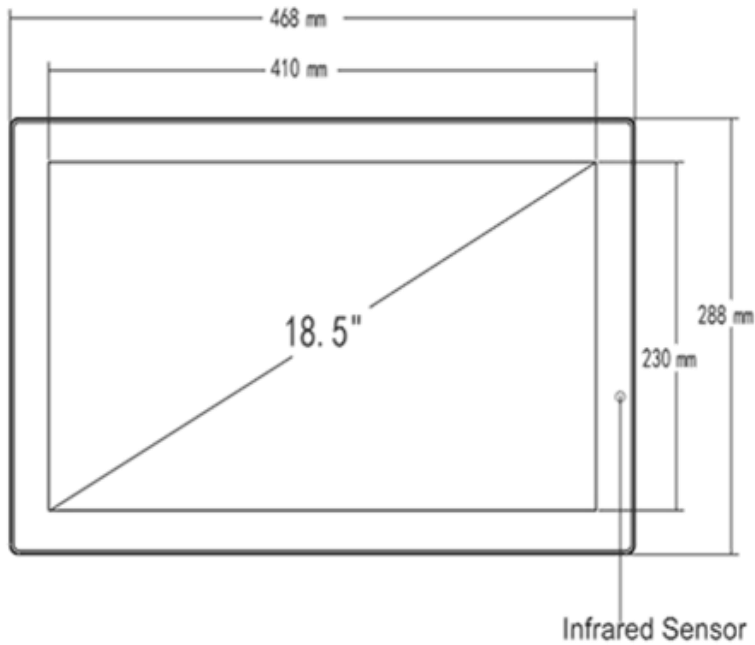

NOTES:
A - VESA MOUNTING POSITIONS x4
SCREEN DEFINITION 1366x768 / 16:9

AD SERIES DISPLAYS MANUFACTURING LTD UNIT 49, ELDON WAY INDUSTRIAL ESTATE, PADDOCK WOOD, TONBRIDGE, KENT, TN12 6BE TEL - 0870 0055 520 www.adseries.com		
PRODUCT CODE		
LAD185P		
PRODUCT NAME		
Qplay		
PRODUCT DESCRIPTION		
QPLAY HD DISPLAYER WITH HDMI		
DRAWING NUMBER		
AD0002-01		
DRAWN BY	APPROVED BY	DATE
RP	MB	12/01/2015
REV	SCALE	SHEET NO.
-	1:5 @ A4	1 OF 1
ALL DIMENSIONS SHOWN IN MILLIMETERS - UNLESS STATED OTHERWISE		THIRD ANGLE PROJECTION
THIS DRAWING IS THE PROPERTY OF 'AD SERIES DISPLAYS MANUFACTURING' AND CONTAINS CONFIDENTIAL AND COPYRIGHT MATERIAL.		
NO PART OF THIS DRAWING MAY BE REPRODUCED OR TRANSMITTED IN ANY FORM OR BY ANY MEANS, ELECTRONIC OR MECHANICAL, FOR ANY PURPOSE, WITHOUT THE EXPRESS WRITTEN PERMISSION OF 'AD SERIES DISPLAYS MANUFACTURING'.		
© 2018 AD SERIES DISPLAYS MANUFACTURING ALL RIGHTS RESERVED		

2018 AD SERIES DISPLAYS MANUFACTURING

21.5" QPLAY LADHD215P

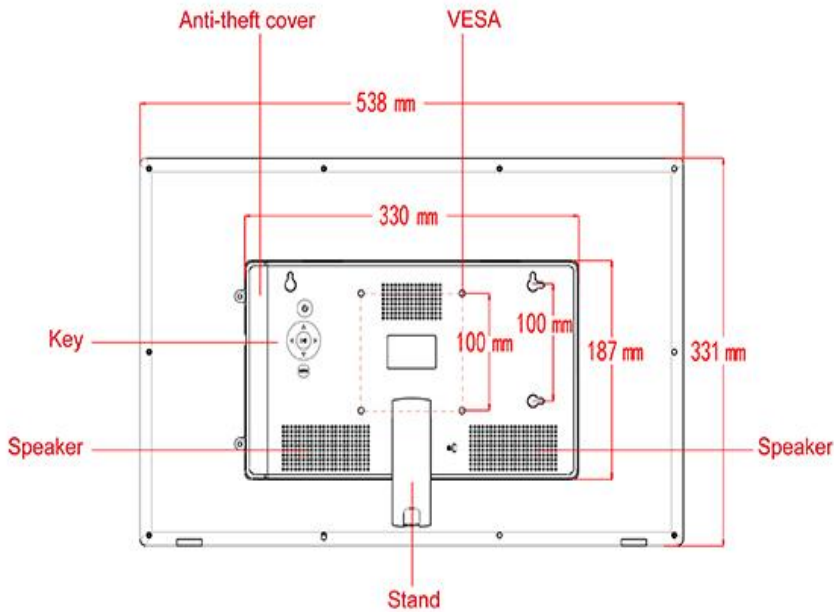
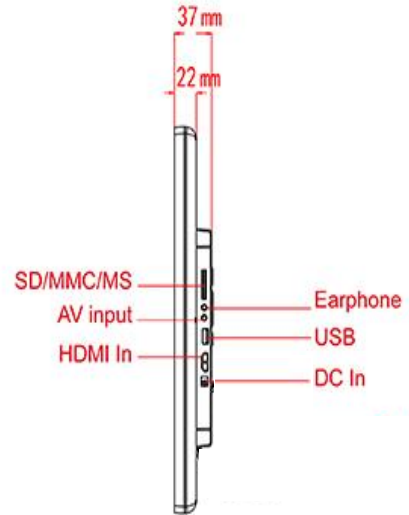
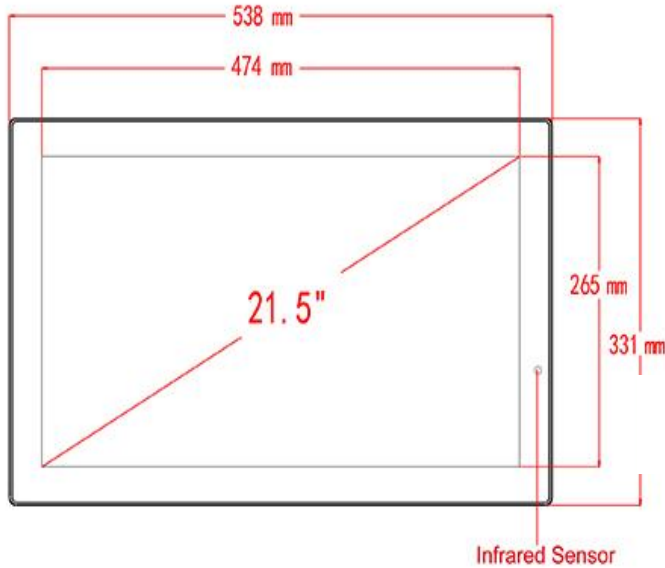

AD SERIES DISPLAYS MANUFACTURING LTD UNIT 49, ELDON WAY INDUSTRIAL ESTATE, PADDOCK WOOD, TONBRIDGE, KENT, TN12 6BE TEL - 0870 0055 520 www.adseries.com		
PRODUCT CODE LADHD215P		
PRODUCT NAME Qplay		
PRODUCT DESCRIPTION QPLAY HD DISPLAYER WITH HDMI		
DRAWING NUMBER AD0003-01		
DRAWN BY RP	APPROVED BY MB	DATE 12/01/2015
REV 1	SCALE NTS	SHEET NO. 1 OF 1
ALL DIMENSIONS SHOWN IN MILLIMETERS - UNLESS STATED OTHERWISE		THIRD ANGLE PROJECTION
THIS DRAWING IS THE PROPERTY OF 'AD SERIES DISPLAYS MANUFACTURING' AND CONTAINS CONFIDENTIAL AND COPYRIGHT MATERIAL.		
NO PART OF THIS DRAWING MAY BE REPRODUCED OR TRANSMITTED IN ANY FORM OR BY ANY MEANS, ELECTRONIC OR MECHANICAL, FOR ANY PURPOSE, WITHOUT THE EXPRESS WRITTEN PERMISSION OF 'AD SERIES DISPLAYS MANUFACTURING'.		
© 2018 AD SERIES DISPLAYS MANUFACTURING ALL RIGHTS RESERVED		

2018 AD SERIES DISPLAYS MANUFACTURING

24" QPLAY LADHD240P

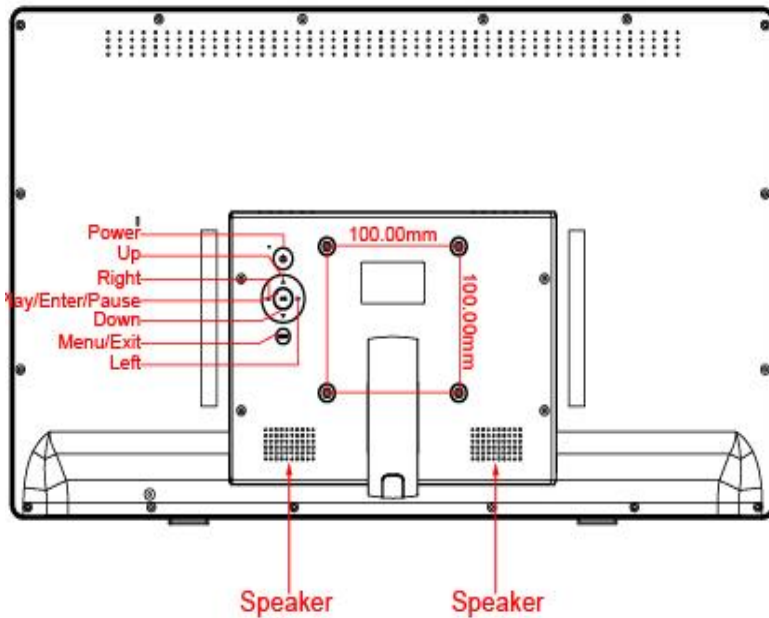
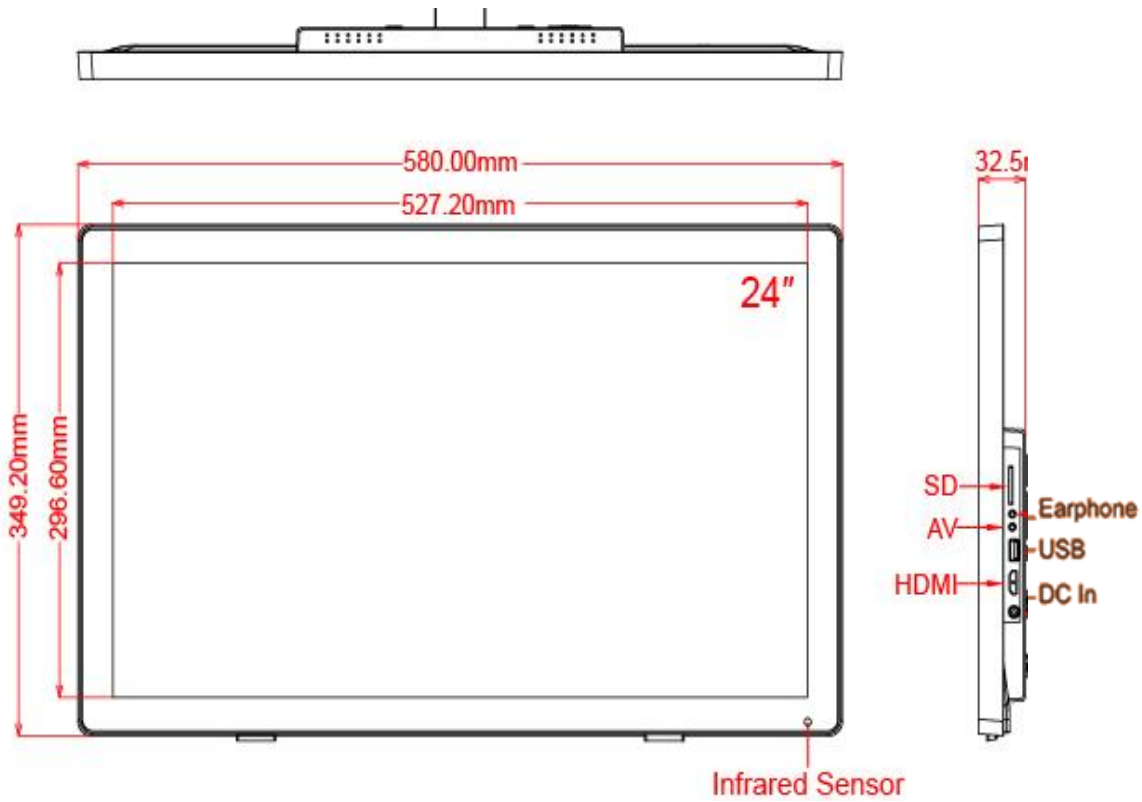

AD SERIES DISPLAYS MANUFACTURING LTD UNIT 49, ELDON WAY INDUSTRIAL ESTATE, PADDOCK WOOD, TONBRIDGE, KENT, TN12 6BE TEL - 0870 0055 520 www.adseries.com	
PRODUCT CODE	LADHD240P
PRODUCT NAME	Qplay
PRODUCT DESCRIPTION	QPLAY HD DISPLAYER WITH HDMI
ALL DIMENSIONS SHOWN IN MILLIMETERS - UNLESS STATED OTHERWISE	THIRD ANGLE PROJECTION
THIS DRAWING IS THE PROPERTY OF AD SERIES DISPLAYS MANUFACTURING AND CONTAINS CONFIDENTIAL AND COPYRIGHT MATERIAL. NO PART OF THIS DRAWING MAY BE REPRODUCED OR TRANSMITTED IN ANY FORM OR BY ANY MEANS, ELECTRONIC OR MECHANICAL, FOR ANY PURPOSE, WITHOUT THE EXPRESS WRITTEN PERMISSION OF AD SERIES DISPLAYS MANUFACTURING.	
© 2018 AD SERIES DISPLAYS MANUFACTURING ALL RIGHTS RESERVED	

2018 AD SERIES DISPLAYS MANUFACTURING

27" QPLAY LADHD270P

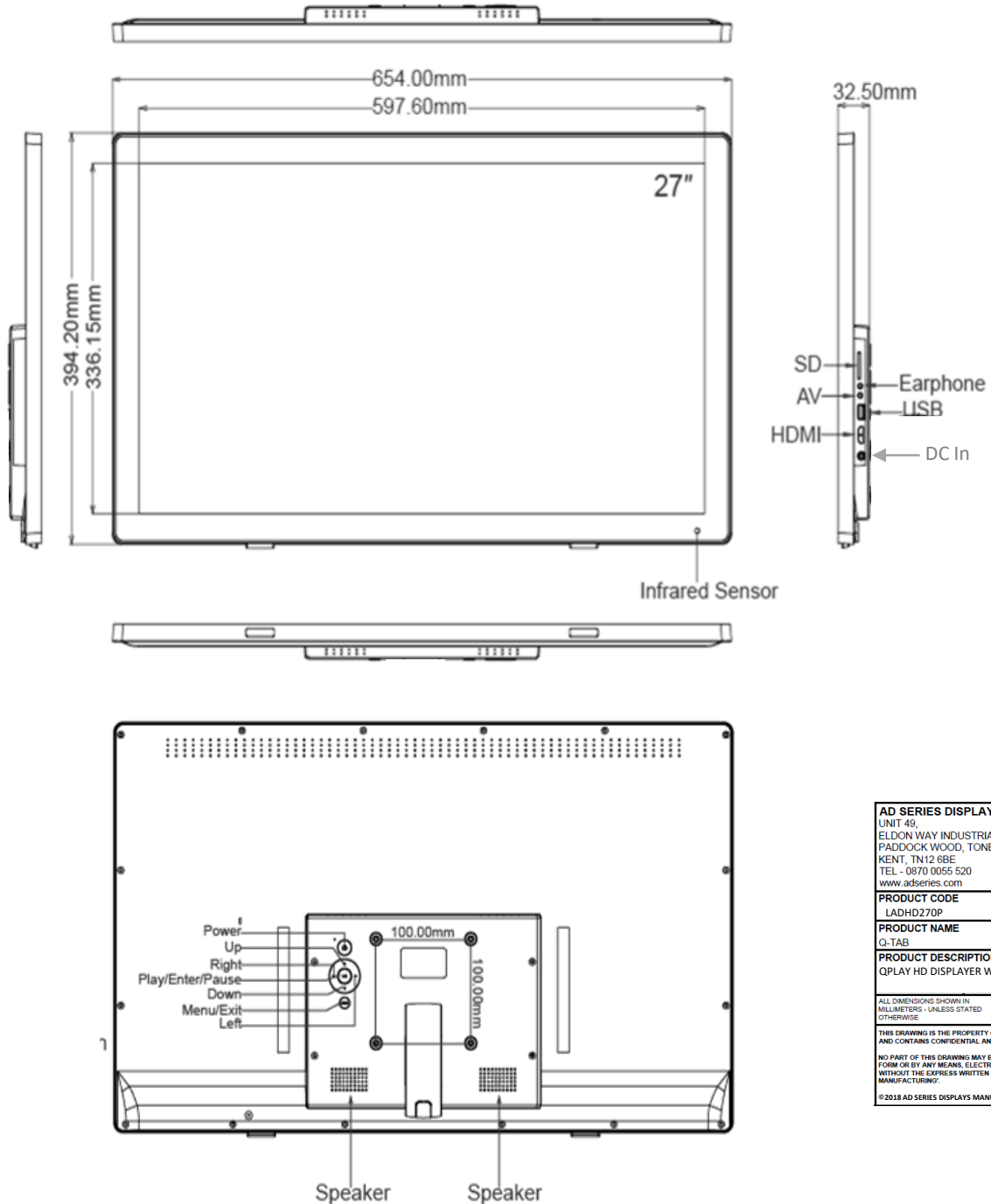

AD SERIES DISPLAYS MANUFACTURING LTD UNIT 49, ELDON WAY INDUSTRIAL ESTATE, PADDOCK WOOD, TONBRIDGE, KENT, TN12 6BE TEL - 0870 0055 520 www.adseries.com	
PRODUCT CODE	
LADHD270P	
PRODUCT NAME	
Q-TAB	
PRODUCT DESCRIPTION	
QPLAY HD DISPLAYER WITH HDMI	
ALL DIMENSIONS SHOWN IN MILLIMETERS - UNLESS STATED OTHERWISE	THIRD ANGLE PROJECTION
THIS DRAWING IS THE PROPERTY OF 'AD SERIES DISPLAYS MANUFACTURING' AND CONTAINS CONFIDENTIAL AND COPYRIGHT MATERIAL. NO PART OF THIS DRAWING MAY BE REPRODUCED OR TRANSMITTED IN ANY FORM OR BY ANY MEANS, ELECTRONIC OR MECHANICAL, FOR ANY PURPOSE, WITHOUT THE EXPRESS WRITTEN PERMISSION OF 'AD SERIES DISPLAYS MANUFACTURING'.	
©2018 AD SERIES DISPLAYS MANUFACTURING ALL RIGHTS RESERVED	

2018 AD SERIES DISPLAYS MANUFACTURING

32" QPLAY LADHD320P

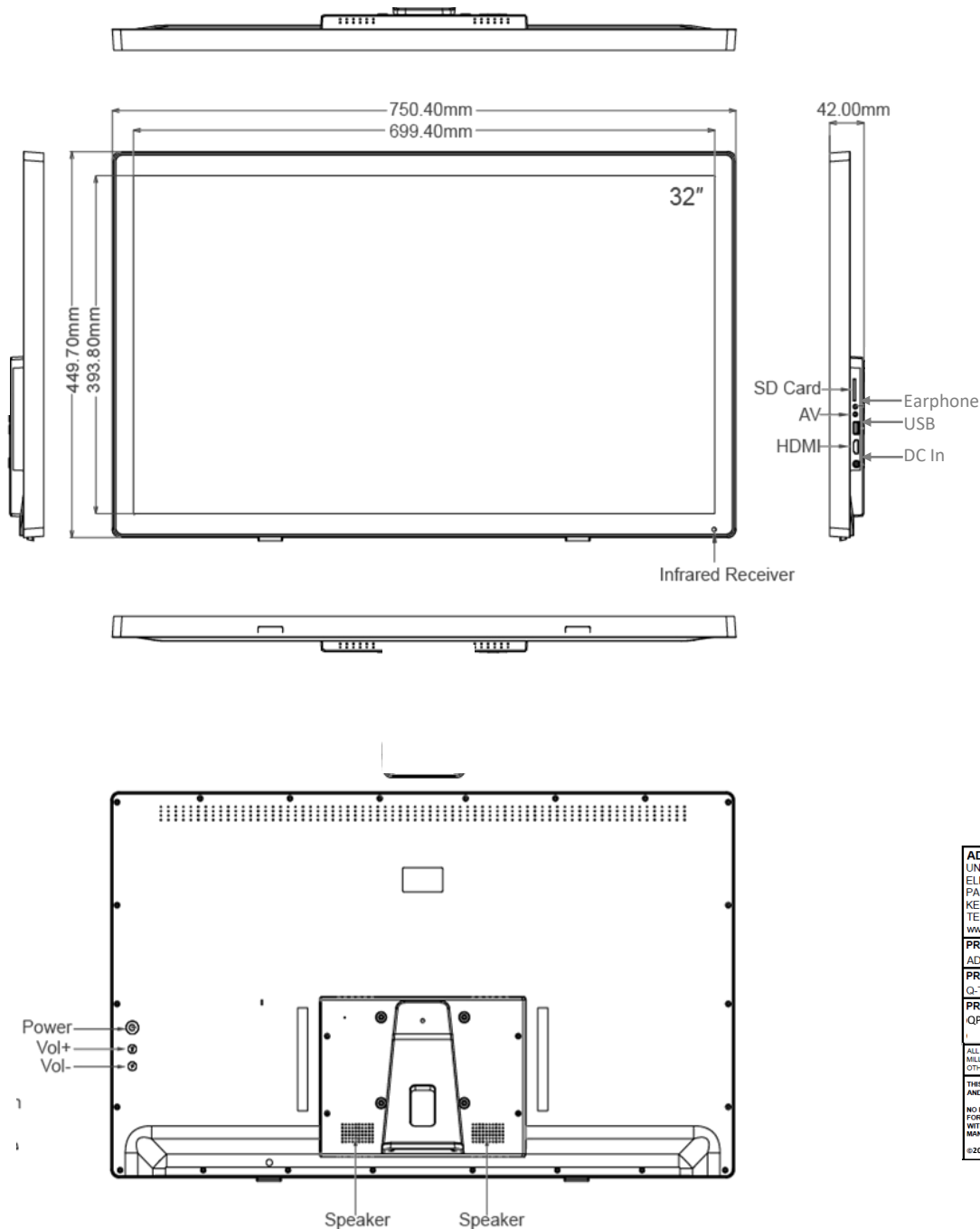

AD SERIES DISPLAYS MANUFACTURING LTD UNIT 49, ELDON WAY INDUSTRIAL ESTATE, PADDOCK WOOD, TONBRIDGE, KENT, TN12 6BE, TEL - 0870 0055 520 www.adseries.com	
PRODUCT CODE AD215PA	
PRODUCT NAME Q-TAB	
PRODUCT DESCRIPTION QPLAY HD DISPLAYER WITH HDMI	
ALL DIMENSIONS SHOWN IN MILLIMETERS - UNLESS STATED OTHERWISE	THIRD ANGLE PROJECTION
<small>THIS DRAWING IS THE PROPERTY OF AD SERIES DISPLAYS MANUFACTURING AND CONTAINS CONFIDENTIAL AND COPYRIGHT MATERIAL. NO PART OF THIS DRAWING MAY BE REPRODUCED OR TRANSMITTED IN ANY FORM OR BY ANY MEANS, ELECTRONIC OR MECHANICAL, FOR ANY PURPOSE, WITHOUT THE EXPRESS WRITTEN PERMISSION OF AD SERIES DISPLAYS MANUFACTURING.</small>	
<small>©2018 AD SERIES DISPLAYS MANUFACTURING ALL RIGHTS RESERVED</small>	

2018 AD SERIES DISPLAYS MANUFACTURING

43" QPLAY LADHD430P

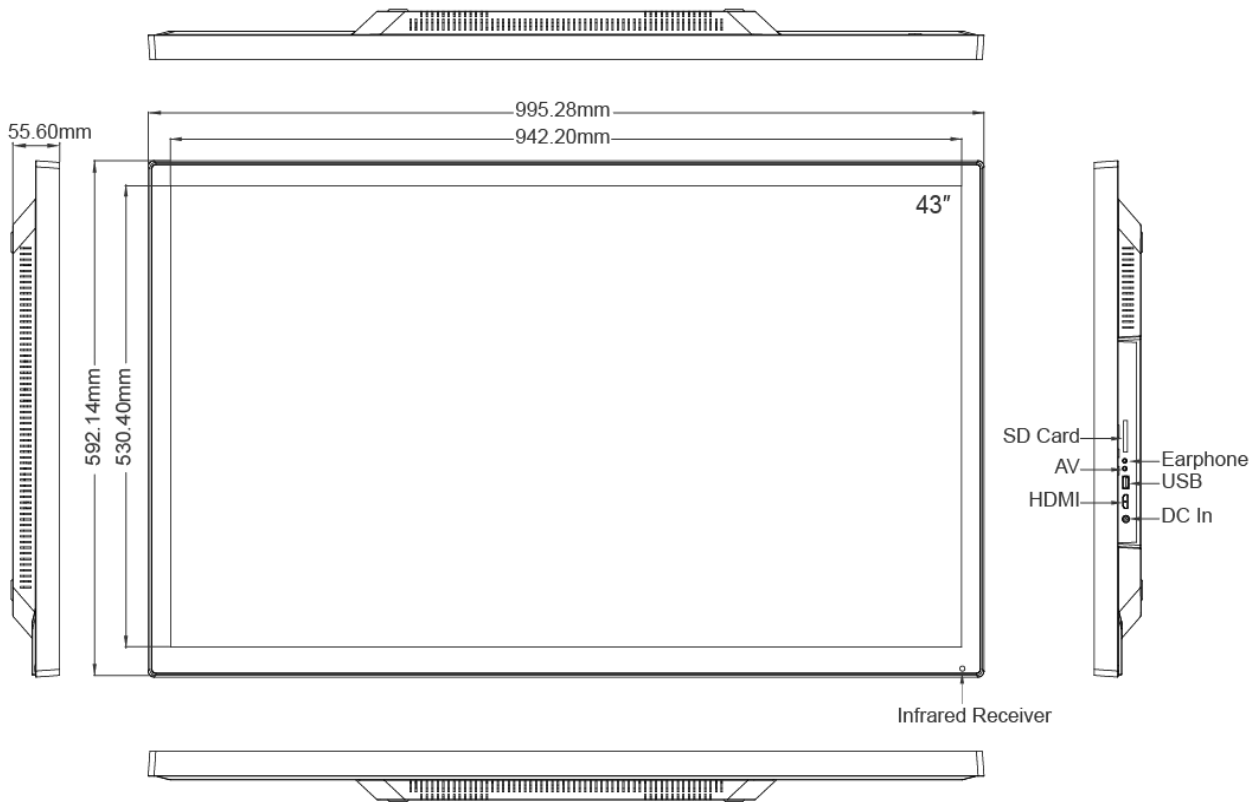

AD SERIES DISPLAYS MANUFACTURING LTD UNIT 49, ELDON WAY INDUSTRIAL ESTATE, PADDOCK WOOD, TONBRIDGE, KENT, TN12 0BE TEL - 0870 0055 520 www.adseries.com	
PRODUCT CODE LADHD430P	
PRODUCT NAME Qplay	
PRODUCT DESCRIPTION QPLAY HD DISPLAYER WITH HDMI	
ALL DIMENSIONS SHOWN IN MILLIMETERS - UNLESS STATED OTHERWISE	THIRD ANGLE PROJECTION
THIS DRAWING IS THE PROPERTY OF 'AD SERIES DISPLAYS MANUFACTURING' AND CONTAINS CONFIDENTIAL AND COPYRIGHT MATERIAL.	
NO PART OF THIS DRAWING MAY BE REPRODUCED OR TRANSMITTED IN ANY FORM OR BY ANY MEANS, ELECTRONIC OR MECHANICAL, FOR ANY PURPOSE, WITHOUT THE WRITTEN PERMISSION OF 'AD SERIES DISPLAYS MANUFACTURING'.	
©2018 AD SERIES DISPLAYS MANUFACTURING ALL RIGHTS RESERVED	

55" QPLAY LADHD550P

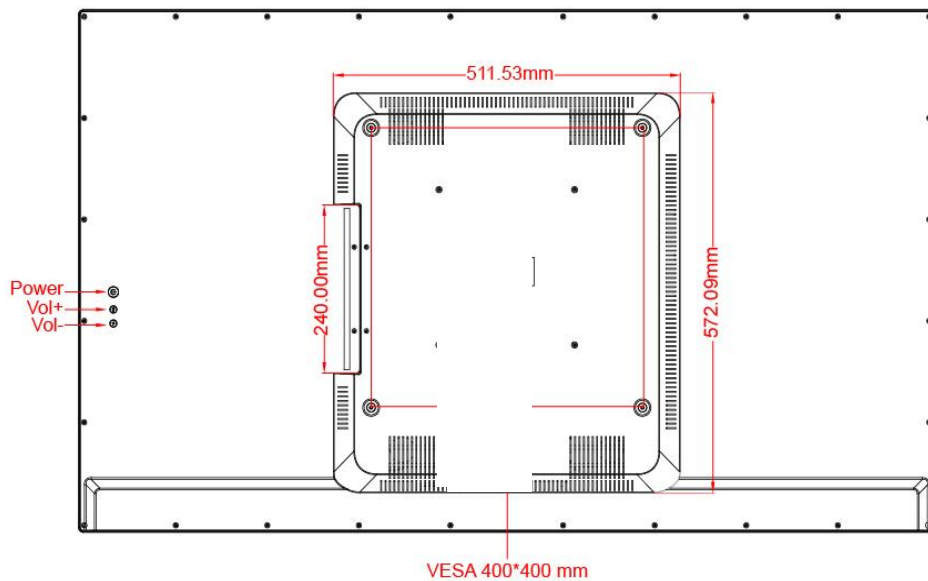
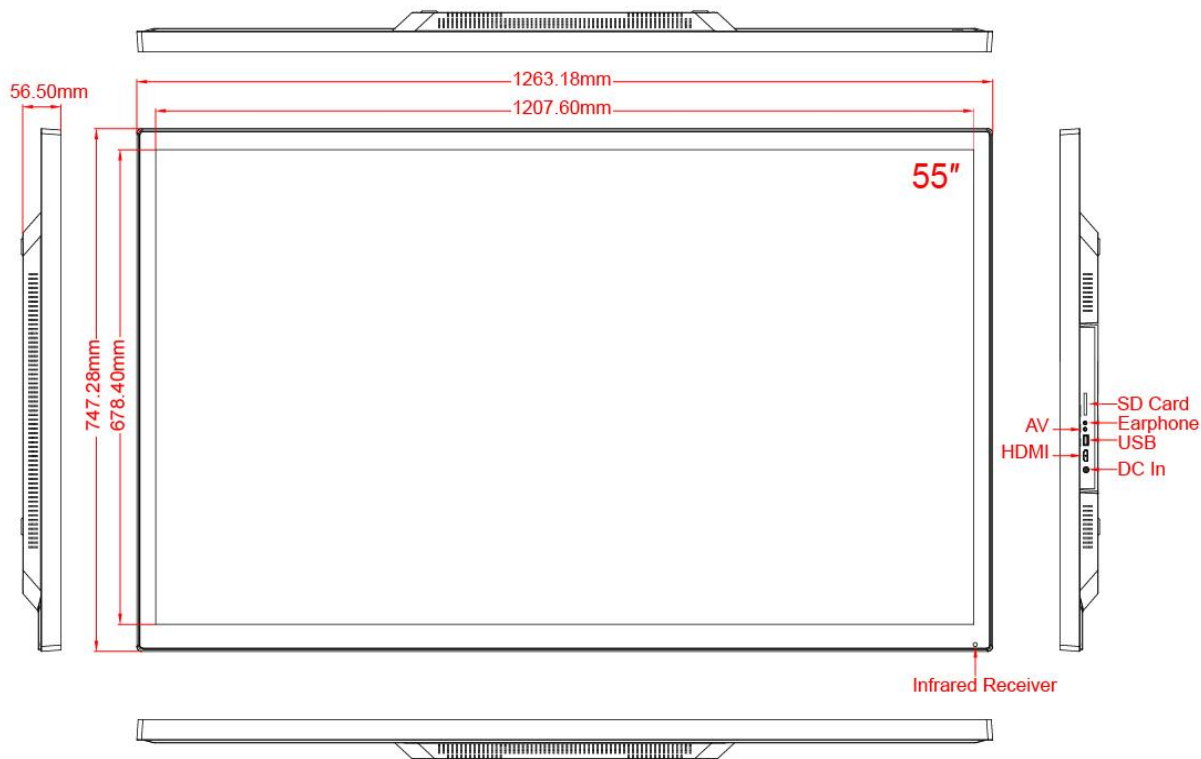

AD SERIES DISPLAYS MANUFACTURING LTD UNIT 49, ELDON WAY INDUSTRIAL ESTATE, PADDOCK WOOD, TONBRIDGE, KENT, TN12 9BE TEL - 0870 0055 520 www.adseries.com	
PRODUCT CODE LADHD550P	
PRODUCT NAME Qplay	
PRODUCT DESCRIPTION QPLAY HD DISPLAYER WITH HDMI	
ALL DIMENSIONS SHOWN IN MILLIMETERS - UNLESS STATED OTHERWISE	THIRD ANGLE PROJECTION
THIS DRAWING IS THE PROPERTY OF 'AD SERIES DISPLAYS MANUFACTURING' AND CONTAINS CONFIDENTIAL AND COPYRIGHT MATERIAL. NO PART OF THIS DRAWING MAY BE REPRODUCED OR TRANSMITTED IN ANY FORM OR BY ANY MEANS, ELECTRONIC OR MECHANICAL, FOR ANY PURPOSE, WITHOUT THE EXPRESS WRITTEN PERMISSION OF 'AD SERIES DISPLAYS MANUFACTURING'.	
©2018 AD SERIES DISPLAYS MANUFACTURING ALL RIGHTS RESERVED. 2018 AD SERIES DISPLAYS MANUFACTURING	